

**TEAC<sup>®</sup>**

**SERVICE MANUAL**

---

**MV3080/6080**

**VCR MECHANISM UNIT**

---



## **CONTENTS**

1. MECHANISM DESCRIPTION .....	2
2. ASSEMBLY DIAGRAM & MAJOR PARTS CHECK .....	5
3. DISASSEMBLY AND REPLACEMENT .....	12
4. MECHANICAL ADJUSTMENT.....	22
5. ADJUSTMENT OF TAPE TRANSPORTING SYSTEM .....	27
6. EXPLODED VIEW AND PARTS LIST.....	37

# 1. DESCRIPTION OF THE MECHANISM

## 1-1 CHARACTERISTIC OF THE K-DECK MECHANISM

- 1) K-MECHA DECK follows the VHS standard.
- 2) K-MECHA DECK uses three motors (DRUM MOTOR, CAPSTAN MOTOR and L/C MOTOR)
- 3) K-MECHA DECK uses L/C MOTOR to drive FRONT LOADING.
- 4) K-MECHA DECK recognizes each mode by using a 4-BIT MODE signal. This 4-BIT MODE signal is generated by the CAM SWITCH which is driven by the L/C MOTOR.
- 5) K-MECHA DECK is operated by 7 MODES (EJECT/INITIAL/REV/IDLE/PLAY, STOP, SLOW/BRAKE/FF & REW).
- 6) K-MECHA DECK reduces the mode shifting time, that is, picture playing time by using the FULL LOADING SYSTEM that has the DRUM wrapped by the tape.
- 7) K-MECHA DECK is seperated from the Main PCB. When assembling, it is connected by B-B TYPE CONNECTOR.  
The CAPSTAN MOTOR and DRUM MOTOR of K-MECHA DECK and the MAIN PCB DECK are directly connected without using cable.

# 1-2 WIRE DIAGRAM

## 1-2-1) WIRE DIAGRAM

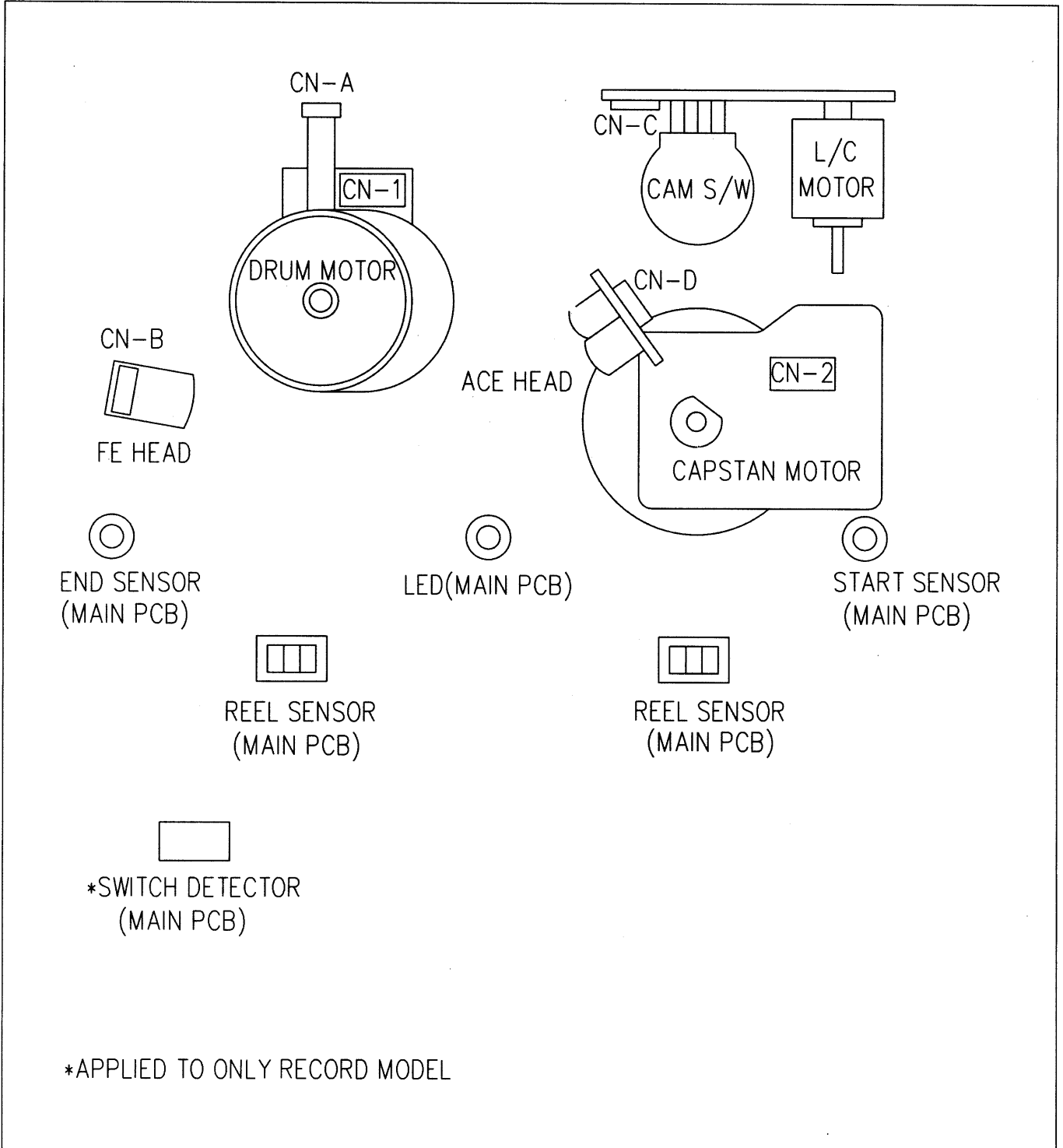

## 1-2-2) CONNECTOR PIN ARRANGEMENT

CN-A (2 HEAD MONO)

1	V-R
2	COMMON
3	V-L
4	GND

CN-A (2 HEAD HI-FI)

1	A-R
2	COMMON
3	A-L
4	GND
5	V-R
6	COMMON
7	V-L

CN-1

1	DRUM M/T 12V
2	DRUM SPP CTL
3	DRUM PG
4	NON CONTACT
5	GND
6	DRUM FG

CN-B

1	FE HEAD
2	GND

CN-A (4 HEAD MONO)

1	SP-L
2	COMMON
3	SP-R
4	GND
5	EP-R/LP-R
6	COMMON
7	EP-L/LP-L

CN-C

1	L/C MT (+)
2	L/C MT (-)
3	GND
4	CAM D
5	CAM C
6	CAM B
7	CAM A

CN-2

1	EVER 5V
2	CAPSTAN F/R
3	CAPSTAN FG
4	CTL-REF
5	CTL
6	I-LIMIT
7	CAPSTAN M/T 12V
8	GND
9	IC GND
10	NON CONTACT

CN-A (4 HEAD HI-FI)

1	SP-L
2	COMMON
3	SP-R
4	GND
5	EP-R/LP-R
6	COMMON
7	EP-L/LP-L
8	A-R
9	COMMON
10	A-L

CN-D

1	CTL
2	CTL
3	AUDIO
4	AUDIO
5	ERASE
6	GND

# 2. ASSEMBLY DIAGRAM & MAJOR PARTS CHECK

## 2-1. ASSEMBLING DIAGRAM

### 2-1-1) ASSEMBLING DIAGRAM OF DECK ASS'Y

#### A. TOP VIEW

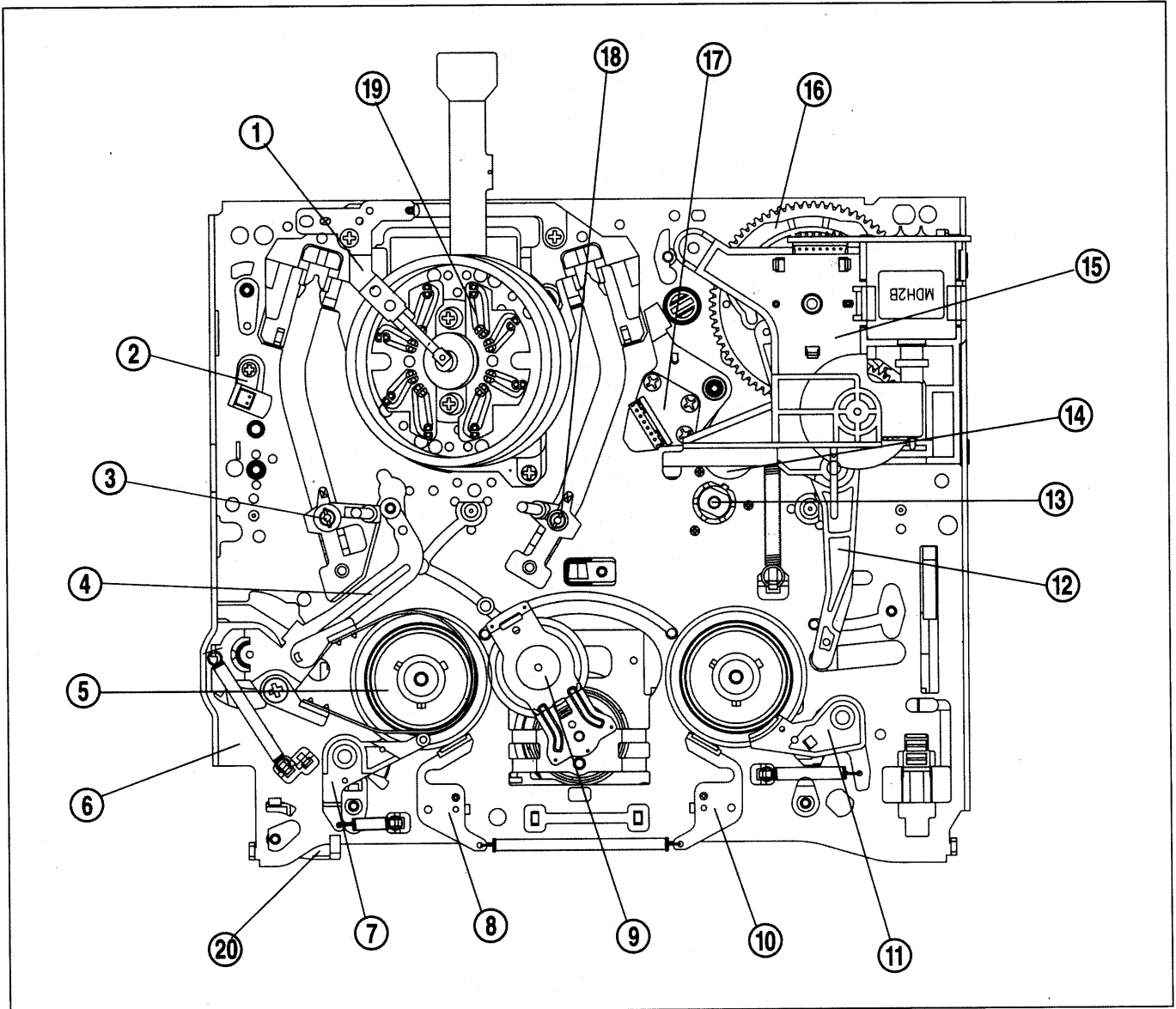

- |                            |                             |
|----------------------------|-----------------------------|
| 1. EARTH BRKT ASS'Y        | 11. T-SUB BRAKE ASS'Y       |
| 2. FE HEAD                 | 12. RELAY LEVER             |
| 3. S SLANT POLE ASS'Y      | 13. CAPSTAN MOTOR           |
| 4. TENSION BAND ASS'Y      | 14. PINCH LEVER TOTAL ASS'Y |
| 5. REEL TABLE              | 15. L/C BRKT TOTAL ASS'Y    |
| 6. MAIN BASE ASS'Y         | 16. CAM GEAR                |
| 7. S SUB BRAKE ASS'Y       | 17. A/C HEAD TOTAL ASS'Y    |
| 8. S MAIN BRAKE ASS'Y      | 18. T SLANT POLE ASS'Y      |
| 9. IDLER PLATE TOTAL ASS'Y | 19. DRUM TOTAL ASS'Y        |
| 10. T MAIN BRAKE ASS'Y     | 20. RECORD SAFETY LEVER     |

## B. BOTTOM VIEW

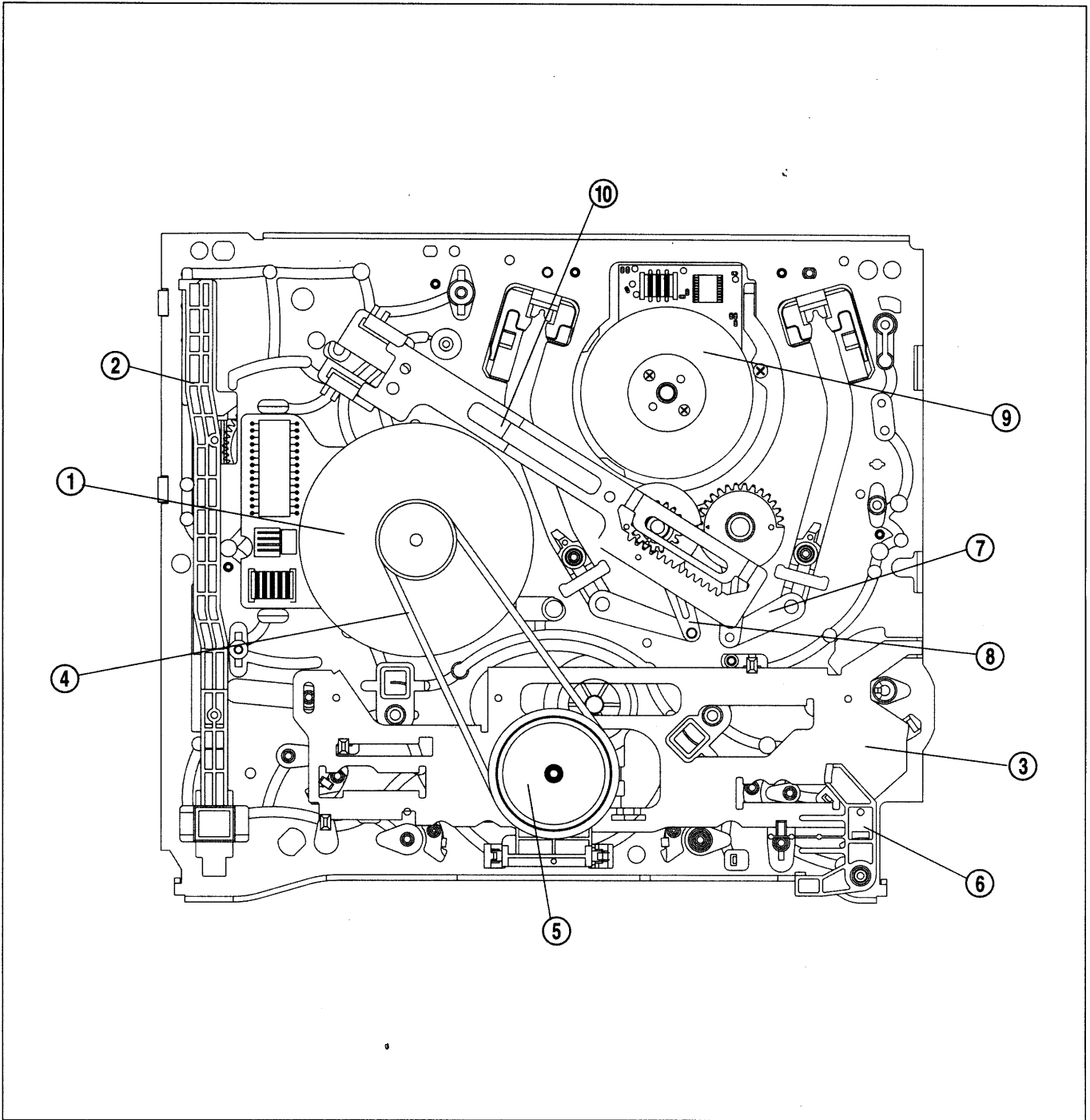

- 1. CAPSTAN MOTOR
- 2. F/L RACK
- 3. CONNECT PLATE
- 4. REEL BELT
- 5. REEL GEAR TOTAL ASS'Y

- 6. RECORD SAFETY LEVER
- 7. L LOADING ASS'Y
- 8. R LOADING ASS'Y
- 9. DRUM TOTAL ASS'Y
- 10. LOADING RACK ASS'Y



## 2-1-2) PARTS LOCATION OF FRONT LOADING ASS'Y

### A. TOP VIEW

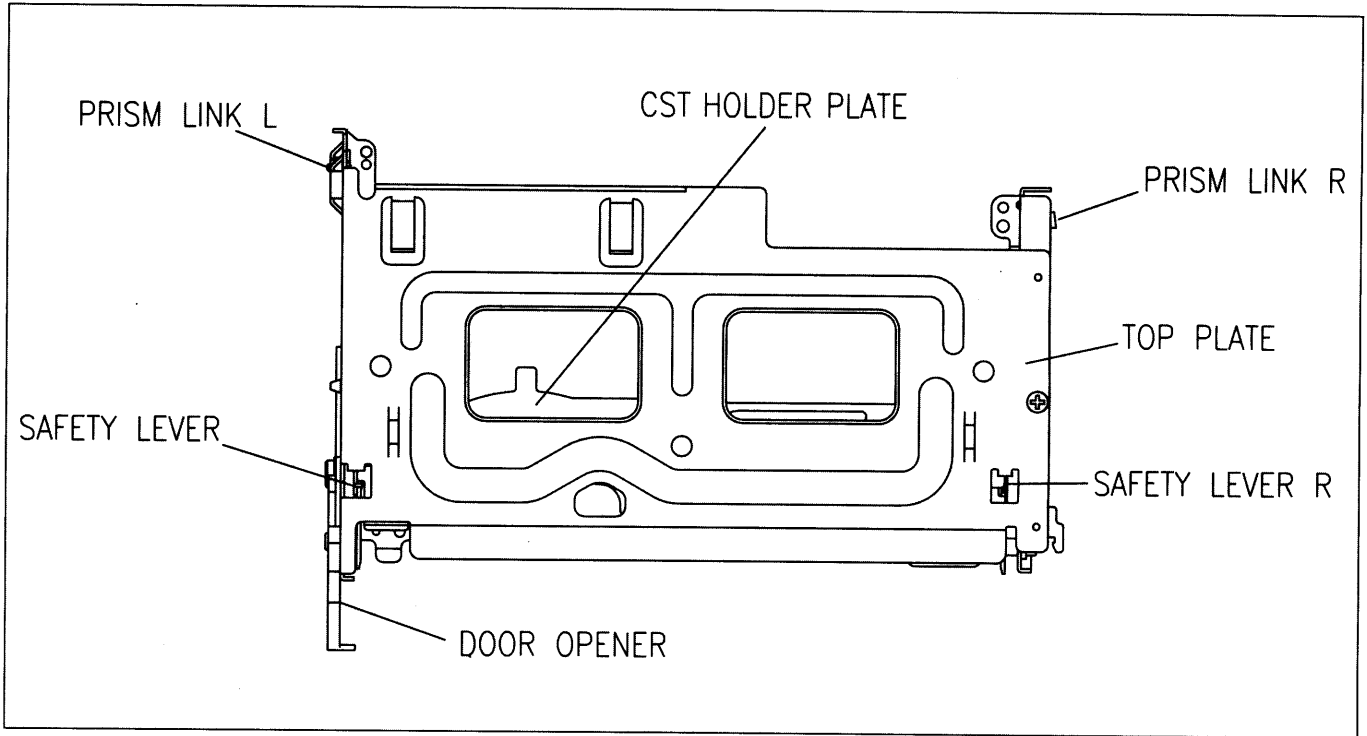

### B. FRONT VIEW

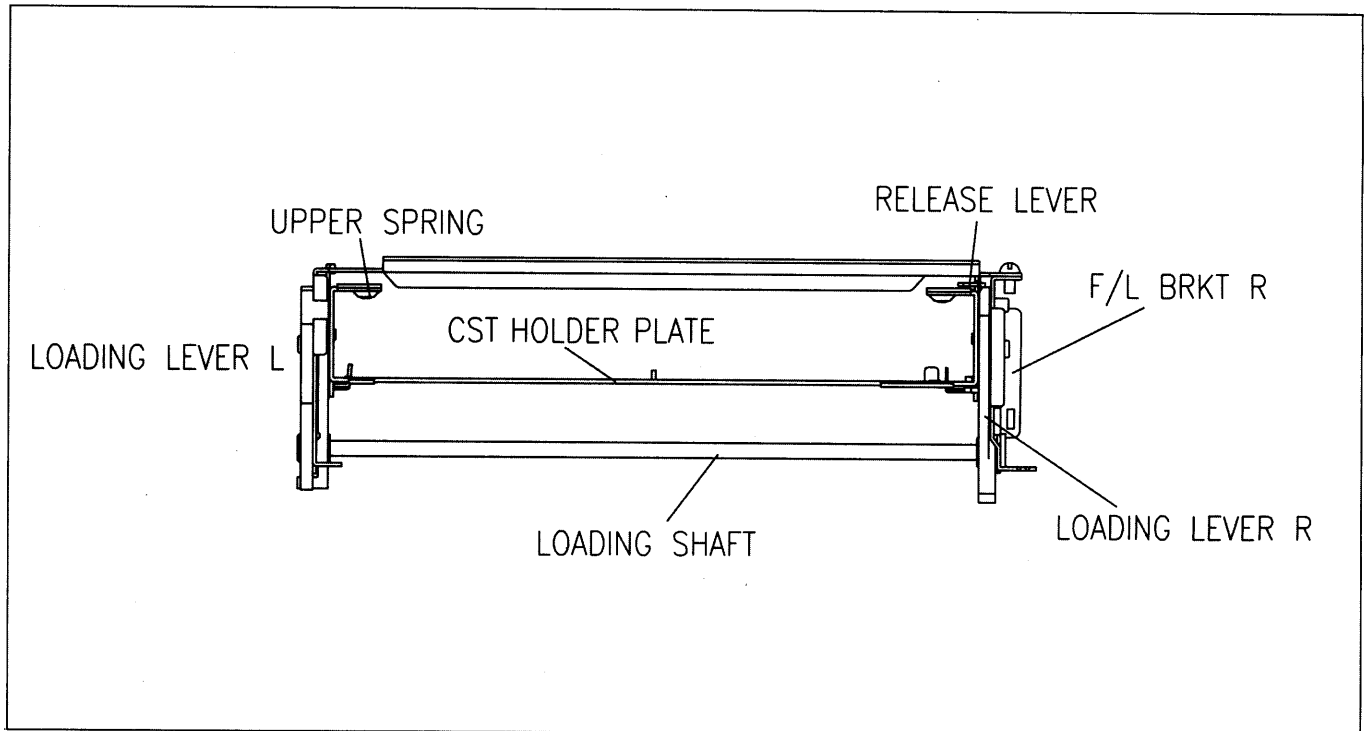

## 2-2. PERIODIC MAINTENANCE AND SERVICE SCHEDULE

### 2-2-1) PERIODIC MAINTENANCE AND SERVICE SCHEDULE

- A. In order to effectively maintain the excellent performance and fully utilize the features of this apparatus, and to lengthen the life of the mechanism and tapes, we strongly urge you to perform periodic maintenance and inspection, as described below.
- ※ After repairing, do the maintenance described below, irrespective of the length of time in use.
- B. Cleaning of the Head Drum Ass'y
- Clean the Drum assembly with a cleaning cloth soaked in liquid cleaner (alcohol) by placing lightly against the Drum and slowly revolving the rotating HEAD DRUM Ass'y by hand (Do not rotate the upper Drum by applying electric power to the motor when cleaning).
  - Do not move the cleaning cloth in the vertical direction against the heat-tip.
- C. Cleaning the tape transporting section.
- Clean the tape transporting parts with a cleaning cloth soaked in alcohol.
- D. Cleaning of driving section
- Clean the driving section with a cloth soaked in alcohol.
- E. Routine inspection
- Perform maintenance and inspection as separately described depending on the period of time in use.
  - Refer to the table of 2-2-3.

### 2-2-2) CLEANING AND LUBRICATION

#### A. Cleaning of Tape Transporting section and Driving section

##### a. Cleaning of Tape Transporting section

— The following parts should be cleaned after every 500 hours of use.

- TENSION POLE
- S SLANT POLE
- AC HEAD/AE HEAD
- S GUIDE POST
- VIDEO HEAD/DRUM
- T GUIDE POST
- FE HEAD
- T SLANT POLE
- CAPSTAN SHAFT
- S GUIDE ROLLER
- T GUIDE ROLLER
- PINCH ROLLER
- VERTICAL POST

— As the above parts contact with the video tape, they tend to collect dust particles. If they are stained with dust or foreign substance it has a bad effect on the picture and may lead to damage of the tape.

— After cleaning with alcohol, allow the parts to dry thoroughly before using a cassette tape.

##### b. Cleaning of Driving section

- REEL TABLE
- CAPSTAN FLYWHEEL/PULLEY
- REEL PULLEY

#### B. LUBRICATION

- S REEL POST
- T REEL TABLE POST
- REEL GEAR POST

— After cleaning these parts with alcohol, lubricate these with one or two drops of oil.

### 2-2-3) SERVICE SCHEDULE FOR THE MAJOR PARTS

The following parts should receive periodic service, according to the recommended intervals.

NAME	PERIODIC SERVICE (TIME)				
	1000	2000	3000	4000	5000
DRUM TOTAL ASS'Y	★	◎	★	◎	★
CAPSTAN MOTOR		◎		◎	
L/C BRKT TOTAL ASS'Y		◎		◎	
REEL BELT		◎		◎	
IDLER PLATE TOTAL ASS'Y		◎		◎	
REEL TABLE			◎		
T SUB BRAKE ASS'Y		◎		◎	
TENSION BAND ASS'Y		◎		◎	
S MAIN BRAKE ASS'Y		◎		◎	
T MAIN BRAKE ASS'Y		◎		◎	
PINCH ROLLER ASS'Y		★	◎	★	
AC HEAD ASS'Y			◎		
FE HEAD					◎
REEL GEAR TOTAL ASS'Y		◎		◎	

★ : Check and Replace if necessary. ◎ : Replace

**Note:** Even though the unit is not used frequently, cleaning, lubrication and replacement of the belt should be undertaken every 2 years.

## 2-3. JIGS AND TOOLS

### 2-3-1) LIST OF JIGS AND TOOLS

NO	ITEMS	MODEL	FIG. NO	REMARKS
1	ALIGNMENT TAPE	NTSC: SP MONOSCOPE 7KHz SP COLORBAR 1KHz (EP MONOSCOPE) PAL/SCAM: SP MONOSCOPE 6KHz SP COLORBAR 1KHz (LP MONOSCOPE)	①	CHECKING OF THE TAPE TRANSPORTING SYSTEM
2	CLEANING TAPE (DAEWOO)	DHC-602V	②	CHECKING OF THE TAPE TRANSPORTING SYSTEM
3	CASSETTE TAPE (KOKUSAI)	KT-300NV KT-300RV	③	MEASUREMENT OF REEL TORQUE
4	VHS SPINDLE HEIGHT GAUGE	TSH-V4	④	MEASUREMENT OF REEL HEIGHT
5	TENTELO METER (TENTELO)	T2-H7-UM	⑤	MEASUREMENT OF THE BACK TENSION
6	FAN TYPE TENSION METER	BELOW 3KG	⑥	MEASUREMENT OF THE PRESSING FORCE FOR THE PINCH ROLLER
7	DENTAL MIRROR		⑦	CHECKING OF THE TAPE TRANSPORTING SYSTEM
8	+DRIVER		⑧-1	ASSEMBLY, DISASSEMBLY AND ADJUSTMENT
	HEX DRIVER		⑧-2	
	ADJUSTMENT DRIVER		⑧-3	

2-3-2) SKETCH OF JIGS AND TOOLS

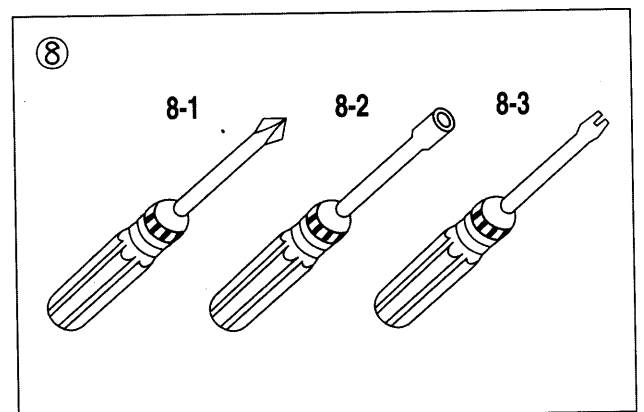
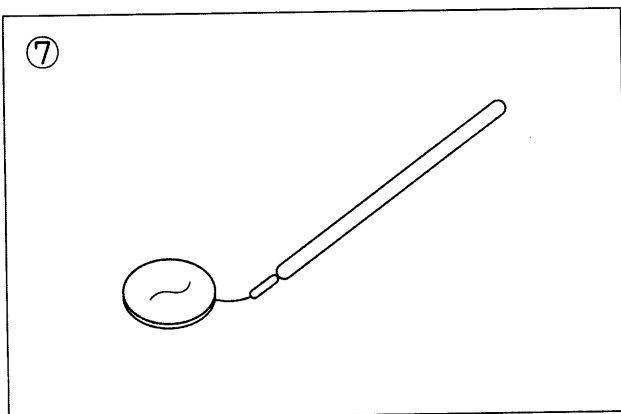
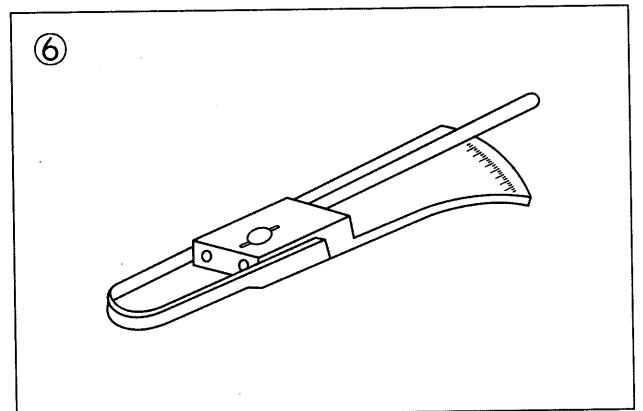
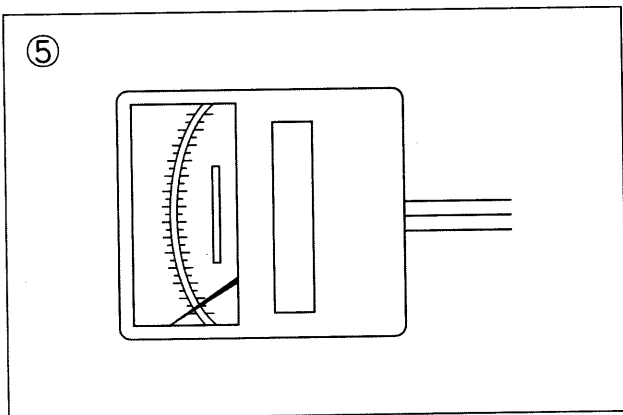
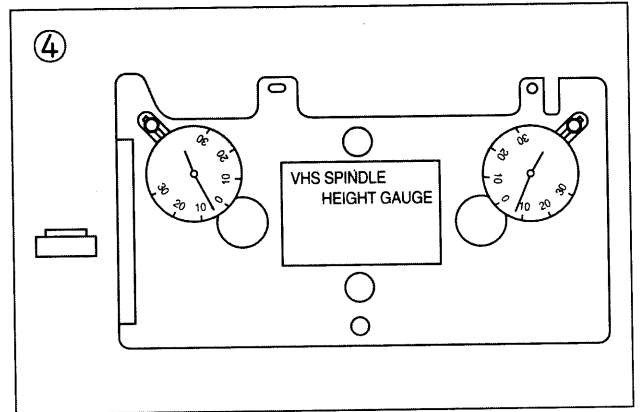
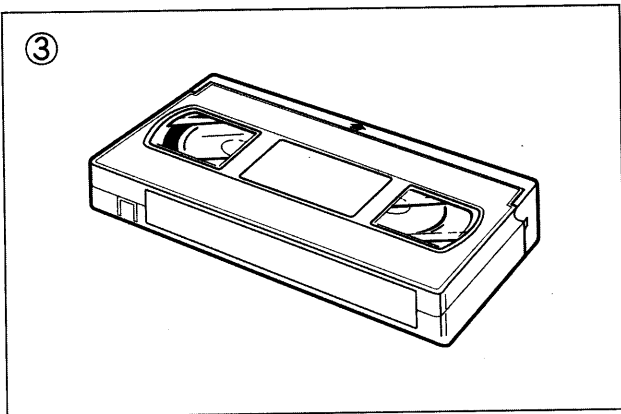
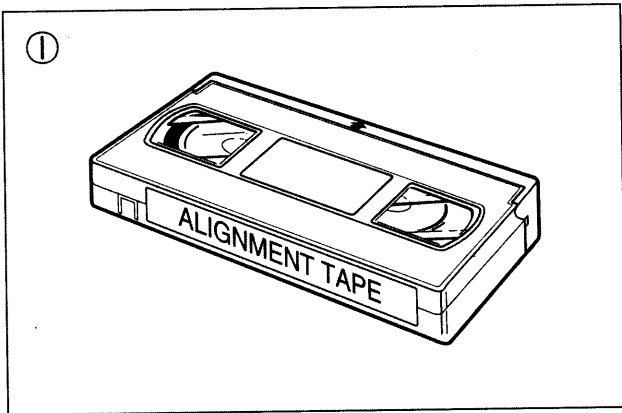

# 3. DISASSEMBLY AND REPLACEMENT

## 3-1. FRONT LOADING ASS'Y REMOVAL (See Fig.3-1)

**NOTE:**

The FRONT LOADING ASSEMBLY can be removed only in the eject position.

- a. Remove 2 screws ① fixing THE FRONT LOADING ASS'Y.

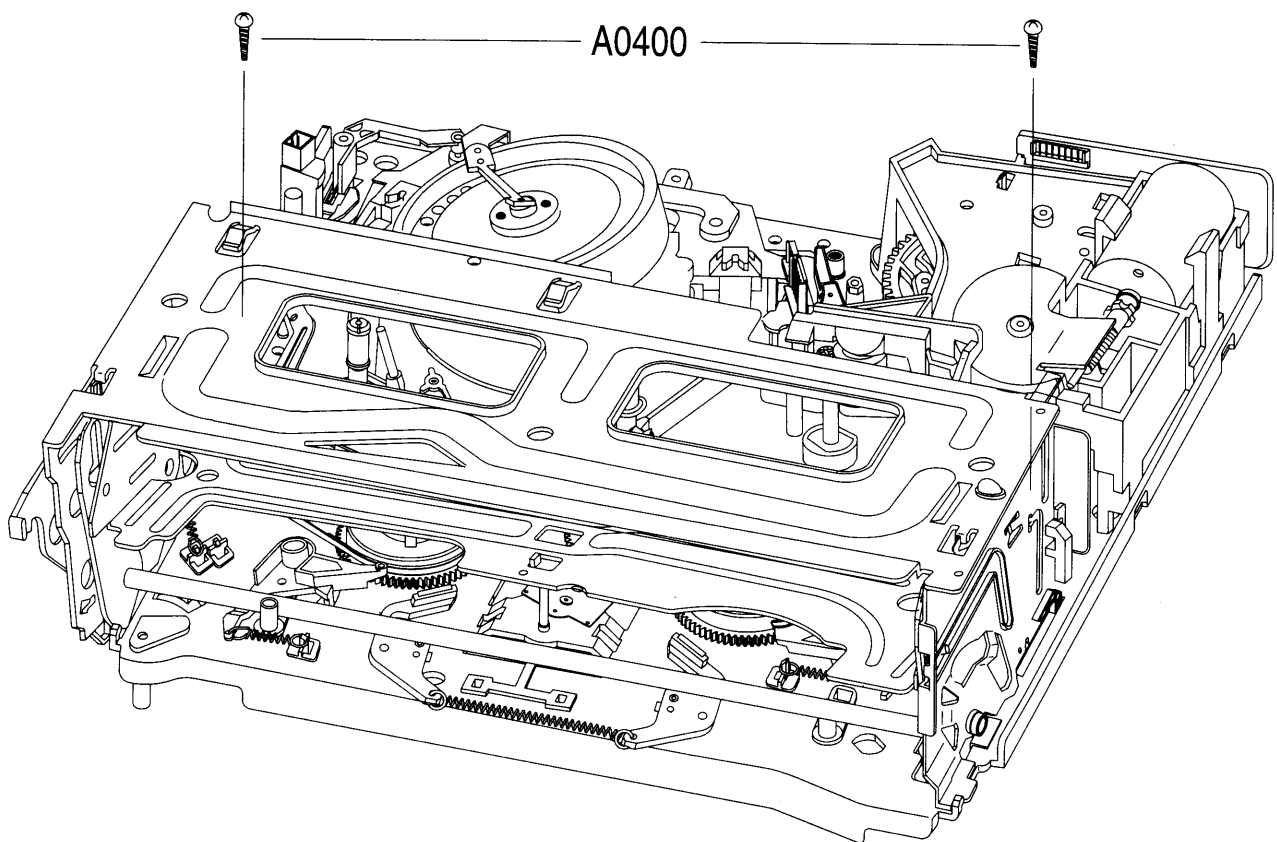

Fig.3-1 FRONT LOADING ASS'Y SEPARATION

### 3-2. DISASSEMBLY OF THE FRONT LOADING ASS'Y (See Fig. 3-2~3-6)

- a. Remove one screw holding the F/L BRACKET R and move the F/L BRACKET R in the direction of arrow to separate it from the TOP PLATE and CASSETTE HOLDER ASSEMBLY.
- b. Remove the CASSETTE HOLDER ASSEMBLY. (Fig. 3-2)

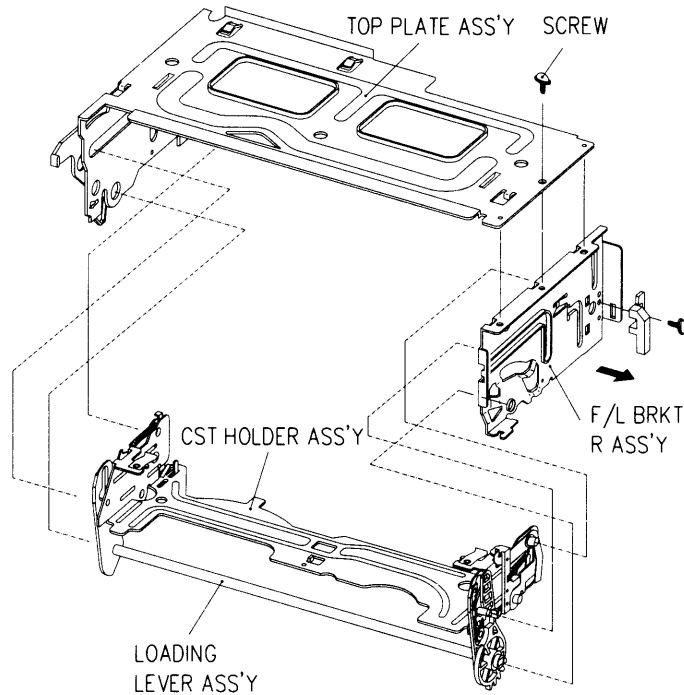

Fig.3-2 DISASSEMBLY OF THE FRONT LOADING ASS'Y

- c. Remove one screw holding the PRISM LINK R and remove the PRISM LINK R from the F/L BRACKET R. (Fig. 3-3)

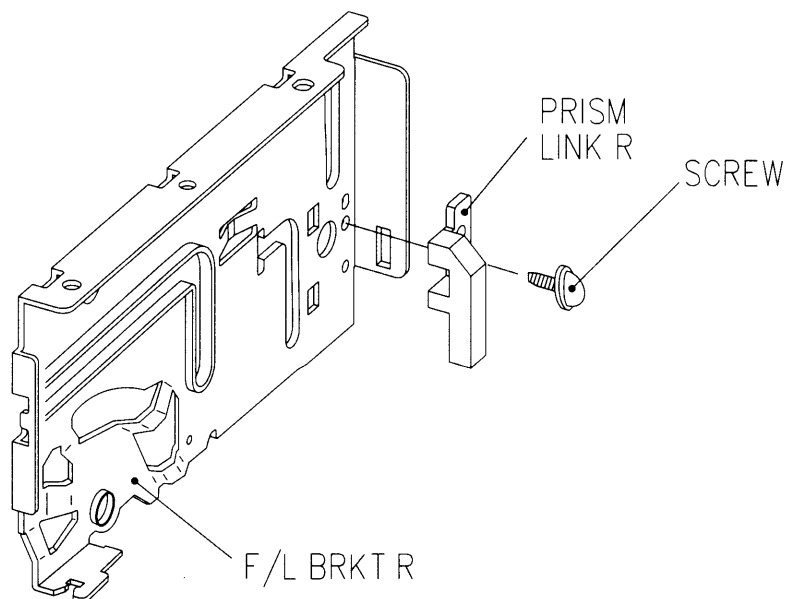

Fig.3-3 DISASSEMBLY OF THE F/L BRKT R

d. Remove one screw holding the PRISM LINK L. (Fig. 3-4)

e. Release the hook B by pushing it in the direction of the arrow and remove the DOOR OPENER. (Fig. 3-4)

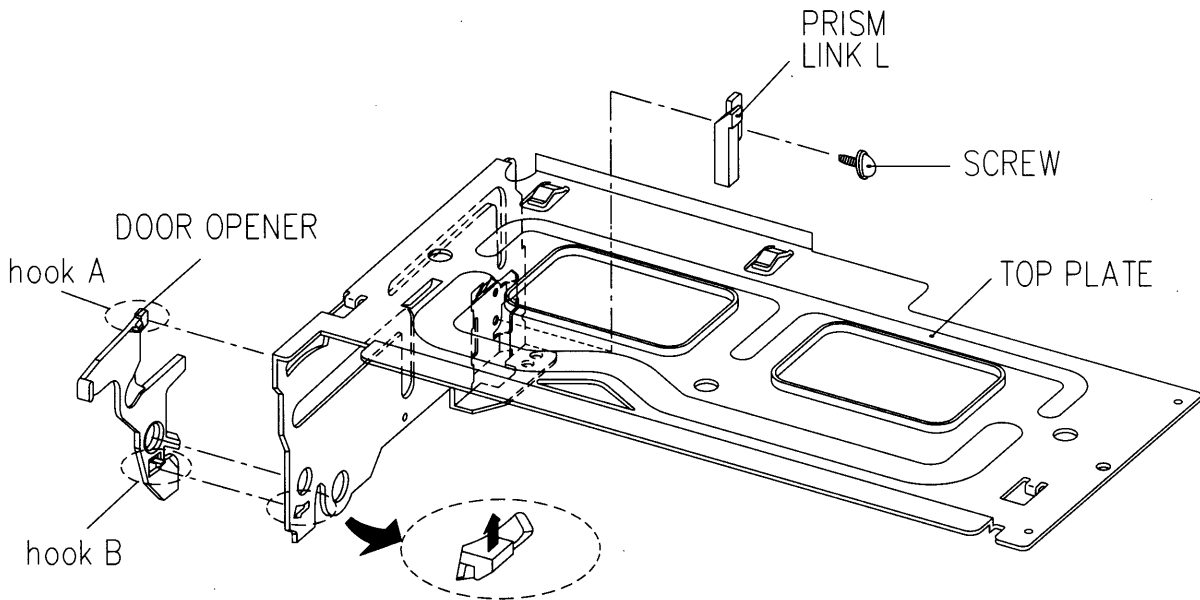

Fig. 3-4 DISASSEMBLY OF THE TOP PLATE

f. Remove the LOADING LEVER ASSEMBLY by pressing the connected section of the loading lever assembly in the directions of the arrows. (Fig. 3-5)

g. Remove the SAFETY SPRING between the SAFETY LEVER and the CASSETTE HOLDER PLATE. (Fig. 3-5)

h. Remove the RELEASE SPRING between the RELEASE LEVER and the SAFETY LEVER R. (Fig. 3-5)

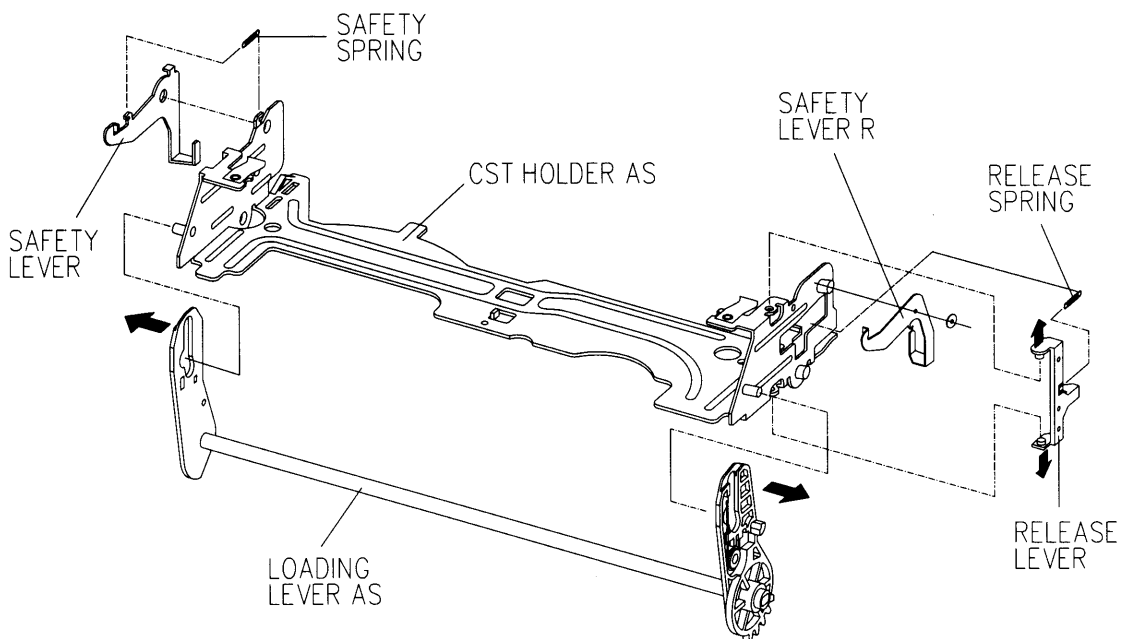

Fig.3-5 DISASSEMBLY OF THE CASSETTE HOLDER ASS'Y



**NOTE:**

Reassemble the FRONT LOADING MECHANISM in the reverse order. Confirm that the two bosses on the left side of the CASSETTE HOLDER AS are inserted into the groove on the left side of the top plate. Insert the two bosses on the right side of the cassette holder into the groove of the F/L BRACKET R (Fig. 3-6)

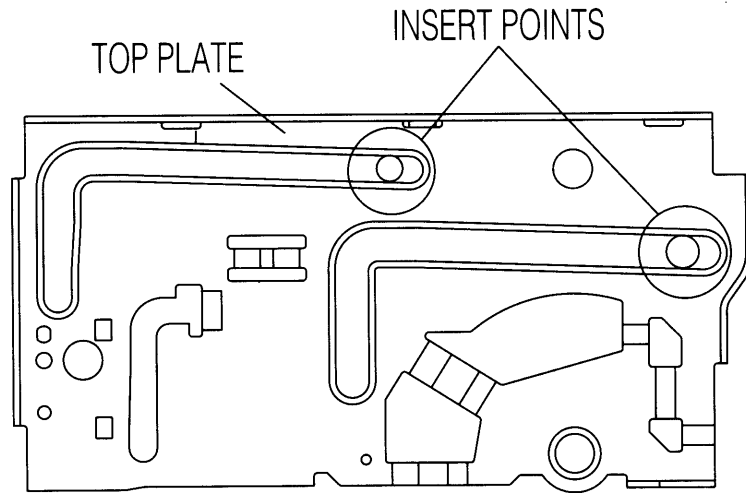

Fig.3-6 ASSEMBLY OF THE F/L ASS'Y

### 3-3. DRUM ASS'Y/EARTH BRACKET ASS'Y REMOVAL (See Fig.3-7)

- Remove three screws ① fixing the DRUM TOTAL ASSEMBLY.
- Remove the EARTH BRACKET ASSEMBLY ②.
- Carefully lift the DRUM TOTAL ASSEMBLY ③ from the DECK MECHANISM, taking care not to damage or touch the VIDEO HEAD.

**NOTE:**

- After assembling the DRUM TOTAL ASSEMBLY, confirm that the TAPE runs smooth and refer to chapter 5 "ADJUSTMENT OF THE TAPE TRANSPORTING SYSTEM".
- When assembling the EARTH BRACKET ASSEMBLY, a 3x12 screw should be used and at the other parts, 3x10 screws should be used.

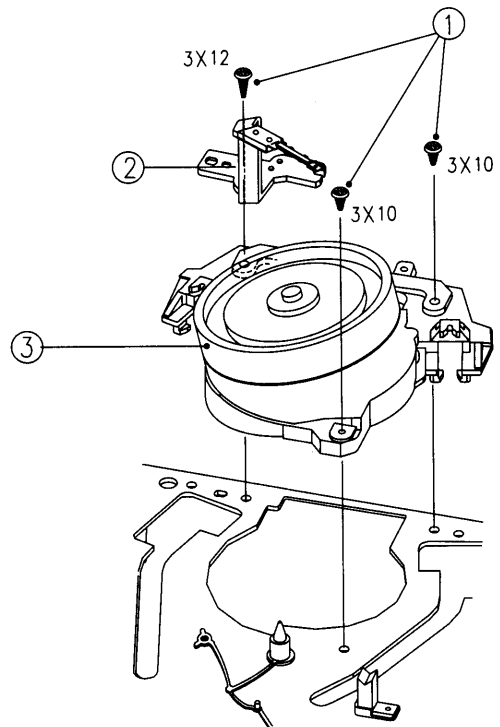

Fig.3-7 DRUM TOTAL ASS'Y & EARTH BRKT ASS'Y REMOVAL

### 3-4. REEL BELT, LOADING RACK ASS'Y, LOADING ASS'Y, S/T SLANT POLE ASS'Y REMOVAL (See Fig.3-8)

- Turn over the DECK MECHANISM and remove the REEL BELT ①.
- Remove one POLY WASHER ②.
- Remove the LOADING RACK ASS'Y ③.
- Remove R & L LOADING ASS'YS ④ and ⑤.
- Remove the S and T SLANT POLES ⑥ and ⑦ by pulling them in the directions of the arrows.

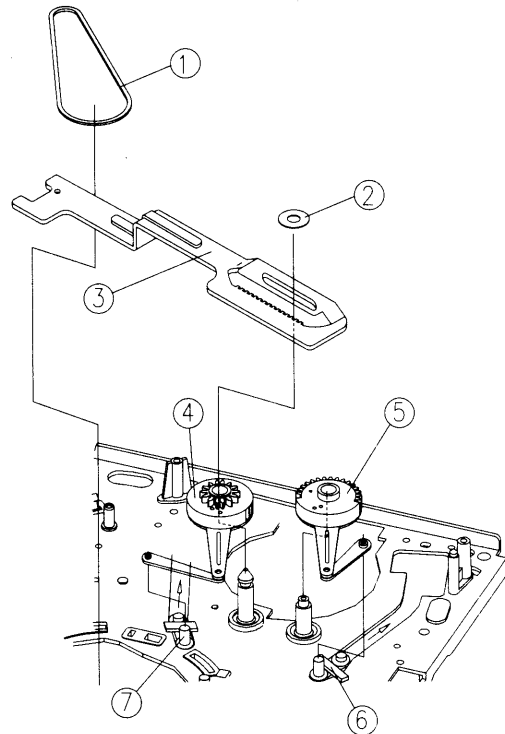

Fig.3-8 REEL BELT, LOADING RACK ASS'Y, R & L LOADING ASS'YS, S/T SLANT POLE ASS'Y REMOVAL

**CAUTION:**

- Take care not to get the GUIDE ROLLERS of the S/T SLANT POLES stained with GREASE
- When reassembling, refer to Fig. 3-9

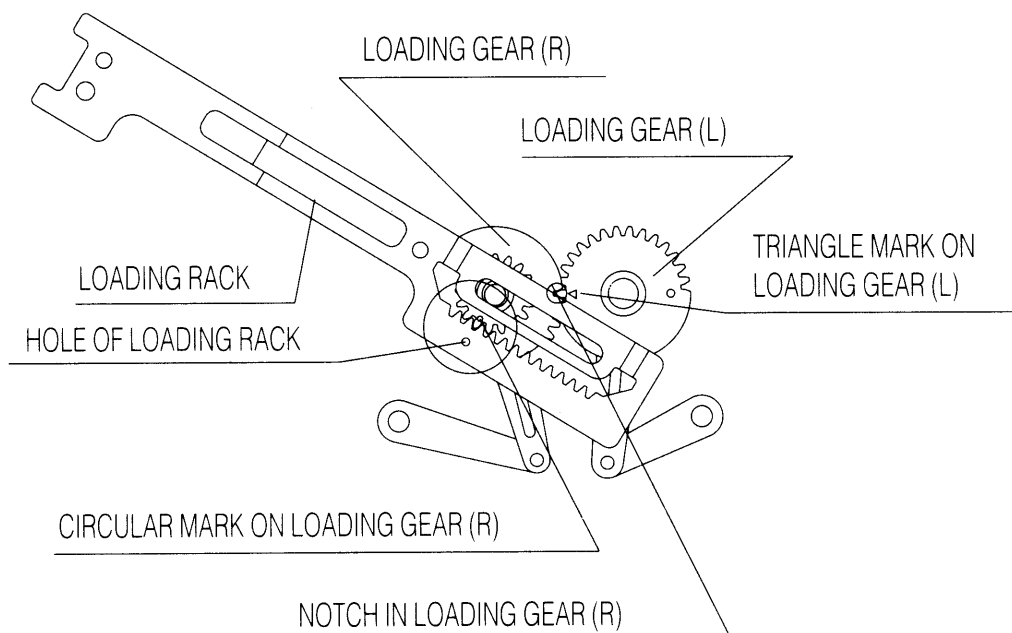

Fig.3-9 ASSEMBLY OF the R.L LOADING ASS'Y & LOADING RACK ASS'Y

### 3-5. A/C HEAD ASS'Y REMOVAL (See Fig.3-10)

- a. Remove one nut hex ① from the A/C HEAD POST ④ of the MAINBASE.
- b. Remove the A/C HEAD ASSEMBLY ② from the MAINBASE.
- c. Remove the A/C HEAD SPRING ③ from the A/C HEAD ASSEMBLY ②.

**NOTE:**

- After reassembling, adjust the TAPE TRANSPORTING SYSTEM referring to chapter 5 "ADJUSTMENT OF THE TAPE TRANSPORTING SYSTEM".
- After adjusting the TAPE TRANSPORTING SYSTEM, spread the A/C HEAD/NUT, AZIMUTH SCREW, and TILT SCREW with LOCKING PAINT.

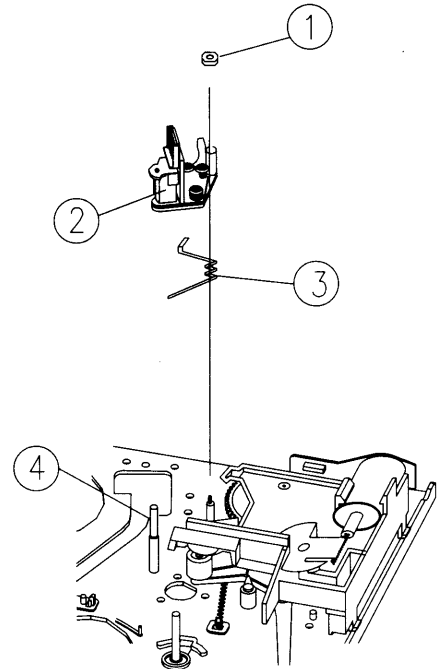

Fig.3-10 DISASSEMBLY OF THE AC HEAD ASS'Y

### 3-6. L/C BRACKET ASS'Y REMOVAL (See Fig.3-11)

- a. Remove one screw ① from the L/C BRACKET ASSEMBLY ②.
- b. Remove the L/C BRACKET ASSEMBLY ② from the MAINBASE.

### 3-7. PINCH LEVER TOTAL ASS'Y REMOVAL (See Fig.3-11)

- a. Remove one POLY WASHER ③ from the PINCH LEVER POST of the MAINBASE.
- b. Unhook the PINCH LEVER SPRING ④ from the hook of MAINBASE ⑤ and remove the PINCH LEVER TOTAL ASSEMBLY ⑨.

**CAUTION:**

Take care not to coat GREASE, OIL or other substances on the surface of the PINCH ROLLER ⑩.

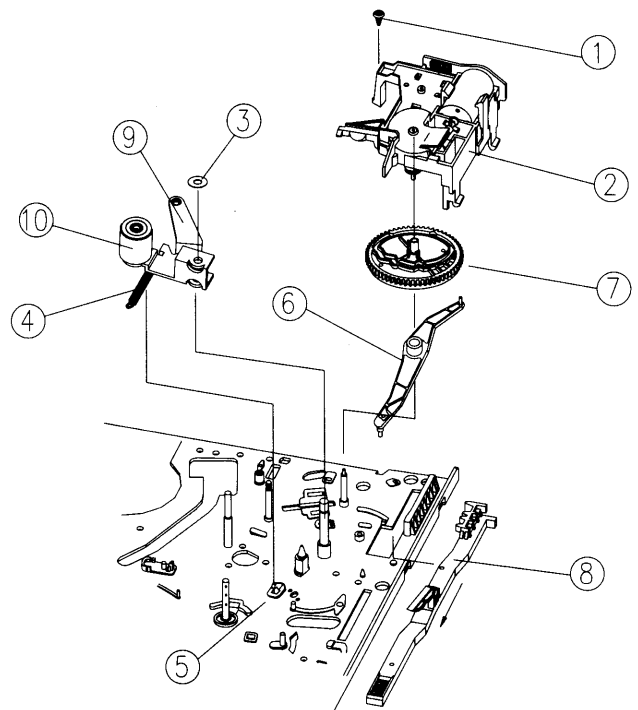

Fig.3-11 L/C BRKT. PINCH LEVER, CAM GEAR, RELAY LEVER, F/L RACK REMOVAL

### 3-8. CAM GEAR, RELAY LEVER AND F/L RACK REMOVAL (See Fig.3-11)

- a. Remove the CAM GEAR ⑦ from the MAINBASE. (Fig.3-11)
- b. Remove the RELAY LEVER ⑥ from the MAINBASE. (Fig. 3-11)
- c. Remove the F/L RACK ⑧ from the MAINBASE by pulling it in the direction of the arrow.

**NOTE:**

When reassembling, refer to Fig. 3-12, 13.

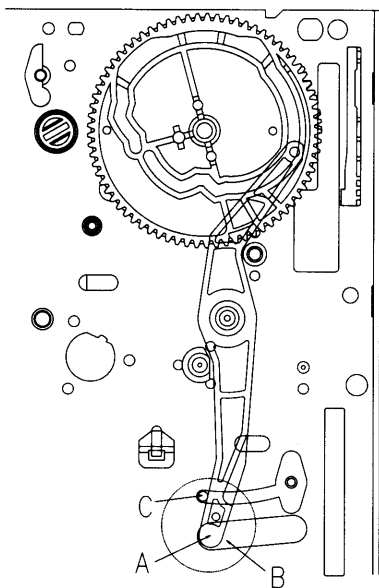

Fig.3-12 ASSEMBLY OF THE CAM GEAR & RELAY LEVER

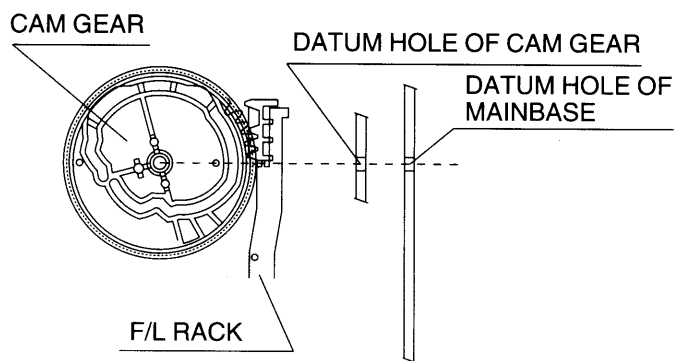

Fig.3-13 ASSEMBLY OF THE CAM GEAR & F/L RACK

### 3-9. S/T MAIN & SUB BRAKE ASS'Y REMOVAL (See Fig.3-14)

- a. Unhook the MAIN BRAKE SPRING ① from the T MAIN BRAKE LEVER ③ and remove the T MAIN BRAKE ASSEMBLY ③.
- b. Remove the S MAIN BRAKE ASSEMBLY ② from the MAINBASE ⑧.
- c. Unhook the S SUB BRAKE SPRING ④ from the MAINBASE and remove the S SUB BRAKE LEVER ASSEMBLY ⑤ from the MAIN BASE ⑧.
- d. Unhook the T SUB BRAKE SPRING ⑥ from the MAINBASE and remove the T SUB BRAKE LEVER ASSEMBLY ⑦.

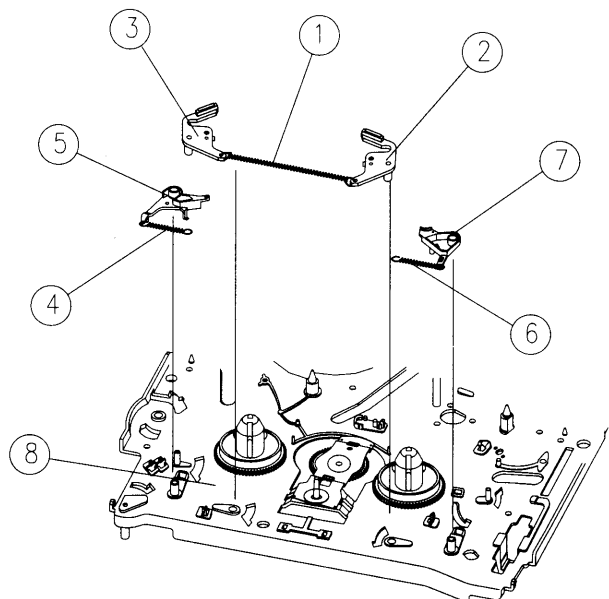

Fig.3-14 S/T MAIN & SUB BRAKES REMOVAL



### 3-11. CAPSTAN MOTOR REMOVAL (See Fig.3-18)

Remove 3 screws fixing the CAPSTAN MOTOR and separate the CAPSTAN MOTOR.

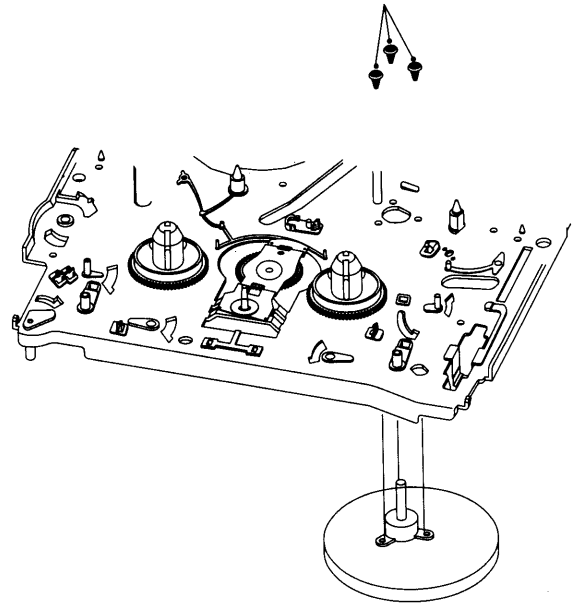

Fig.3-18 CAPSTAN MOTOR REMOVAL

### 3-12. IDLER PLATE TOTAL ASS'Y & S/T REEL TABLE REMOVAL (See Fig.3-19)

- a. Remove one POLY WASHER ① from the REEL GEAR POST ② and remove the IDLER PLATE TOTAL ASSEMBLY ③ from the MAIN BASE.
- b. Remove the S/T REEL TABLES ④ and two POLY SLIDERS ⑤ from the DECK MECHANISM.

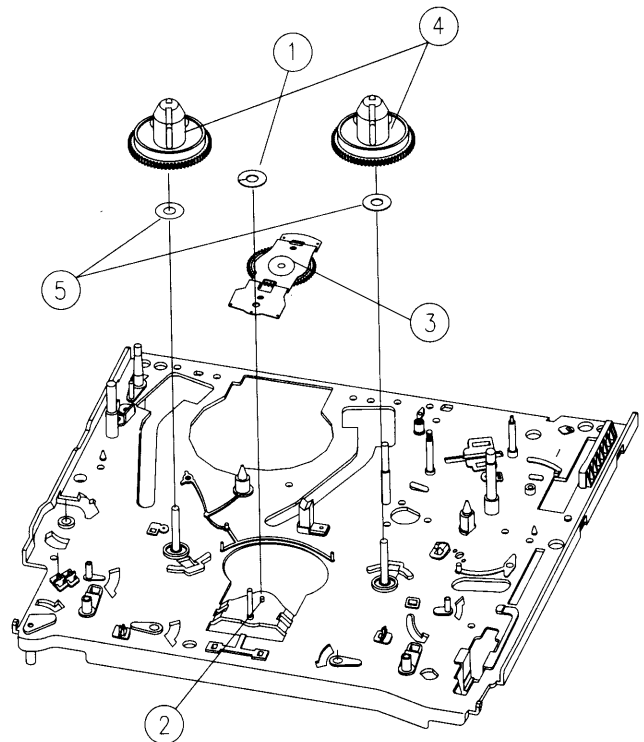

Fig.3-19 IDLER PLATE TOTAL ASS'Y & S/T REEL TABLES REMOVAL

**CAUTION:**

- When disassembling or assembling the IDLER PLATE TOTAL ASSEMBLY, take care not to bend it.

### 3-13. FE HEAD REMOVAL (See Fig.3-20)

Remove one screw ① fixing the FE HEAD and remove the FE HEAD ② from the MAINBASE.

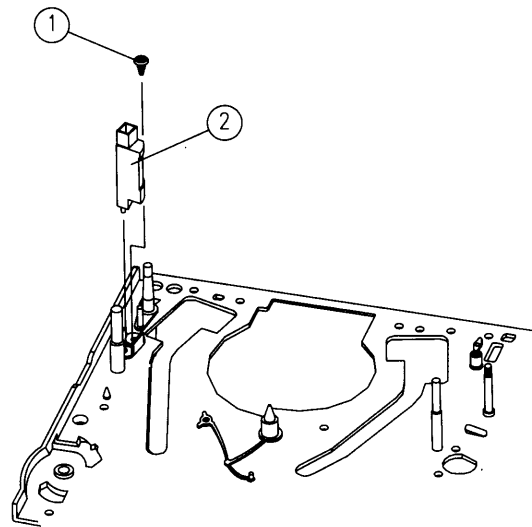

Fig.3-20 FE HEAD REMOVAL

### 3-14. REEL GEAR TOTAL ASS'Y & CONNECT PLATE REMOVAL (Fig.3-21)

- a. Turn over the DECK MECHANISM and remove one POLY WASHER ① from the REEL GEAR POST ②.
- b. After separating tab 'B' of the MAINBASE, remove the REEL GEAR TOTAL ASSEMBLY ③ from the MAINBASE.
- c. Remove the CONNECT PLATE ④ from the MAINBASE by pushing it in the direction of the arrow.

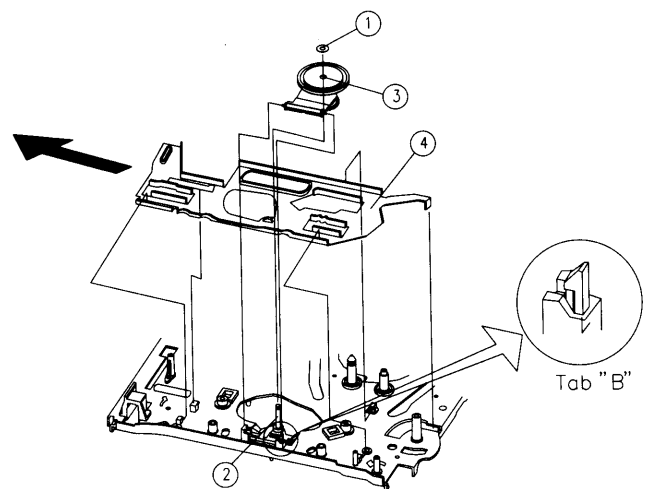

Fig.3-21 REEL GEAR TOTAL ASS'Y & CONNECT PLATE REMOVAL

#### NOTE:

- When removing the CONNECT PLATE with the F/L RACK installed, take care not to damage or bend the CONNECT PLATE.
- After assembling or disassembling the REEL GEAR TOTAL ASSEMBLY, take care not to get OIL, GREASE or other substances on the REEL BELT.
- Take care not to deform or break tab "B".
- Check the assembly state & the operating state of the REEL GEAR TOTAL ASSEMBLY before assembling.
- After reassembling, check the FF, REW, PLAY and REVIEW MODES and the existence of noise when operating the MODES.

# 4. MECHANICAL ADJUSTMENT

## 4-1. MECHANICAL ADJUSTMENT (See Fig.4-1~4-5)

When operational problems occur or the mechanism is reassembled, be sure to confirm the following INSTRUCTIONS.

- a. Make sure that the DATUM HOLE of the CAM GEAR is aligned with the DATUM HOLE in the MAINBASE in the EJECT mode, as shown in Fig.4-1.

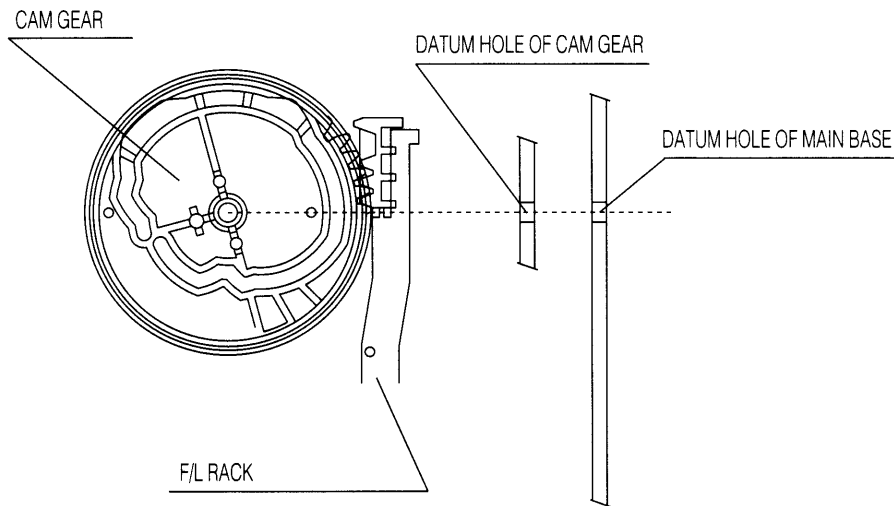

Fig.4-1 DATUM POSITION OF F/L RACK & CAM GEAR

- b. Make sure that part "A" of the RELAY LEVER, when assembled in the CONNECT PLATE, is fully rotated to the left side of "B" of the MAINBASE, and is touching boss "C" of the MAINBASE as, shown in Fig.4-2.

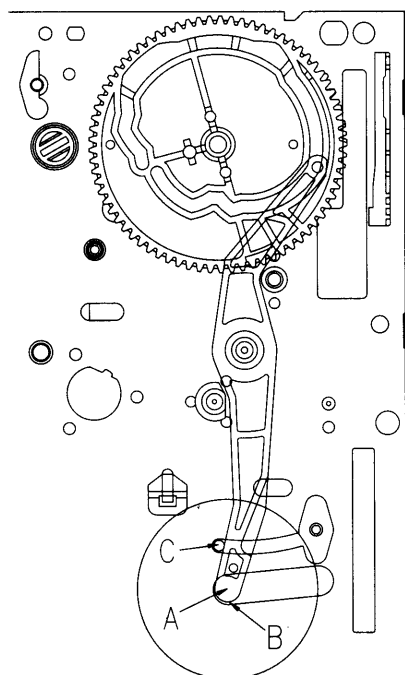

Fig.4-2 DATUM POSITION OF RELAY LEVER & CAM GEAR



- c. When reassembling the L/C BRACKET TOTAL ASSEMBLY on the MAINBASE, make sure that the two triangular marks of CAM SWITCH are aligned with each other as shown in Fig.4-3.

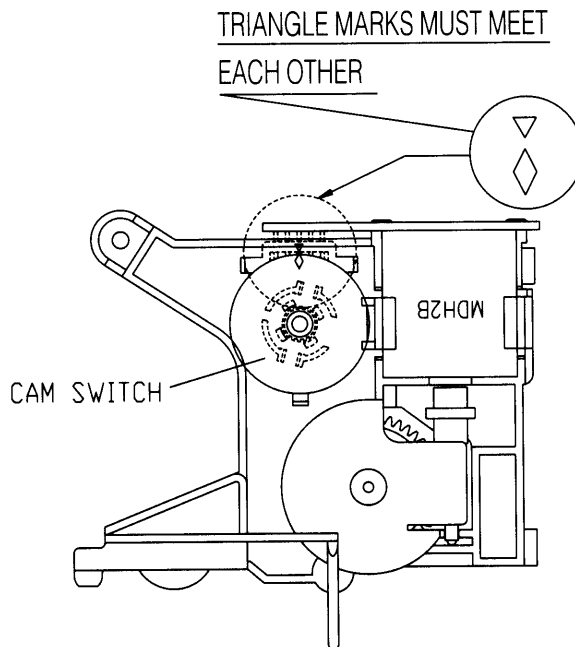

Fig.4-3 DATUM POSITION OF CAM SWITCH TRIANGULAR MARKS

- d. Make sure that boss "A" of the PINCH LEVER TOTAL ASSEMBLY is positioned at point "B" of the CAM GEAR, as shown in Fig.4-4.

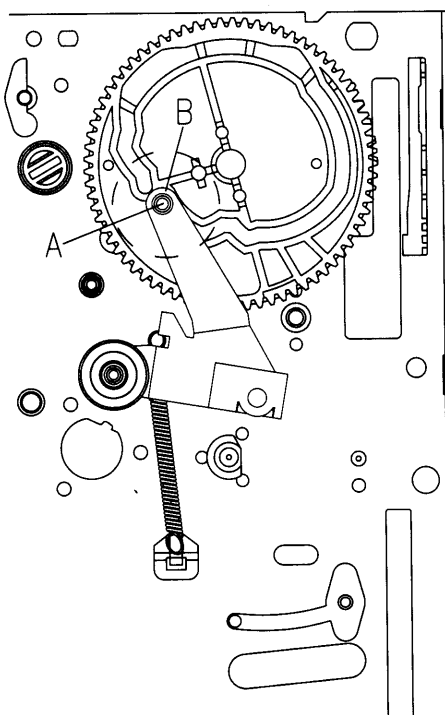

Fig.4-4 DATUM POSITION OF PINCH LEVER TOTAL ASS'Y & CAM GEAR

- e. Make sure that the triangular mark "A" on the L LOADING ASSEMBLY is aligned with the notch "B" on the R LOADING ASSEMBLY as shown in Fig. 4-5.
- f. Make sure that the teeth of the LOADING RACK ASSEMBLY are aligned with those of the R LOADING ASSEMBLY so that the hole of the LOADING RACK ASSEMBLY aligns with the circular mark on the R LOADING ASSEMBLY, as shown in Fig.4-5.

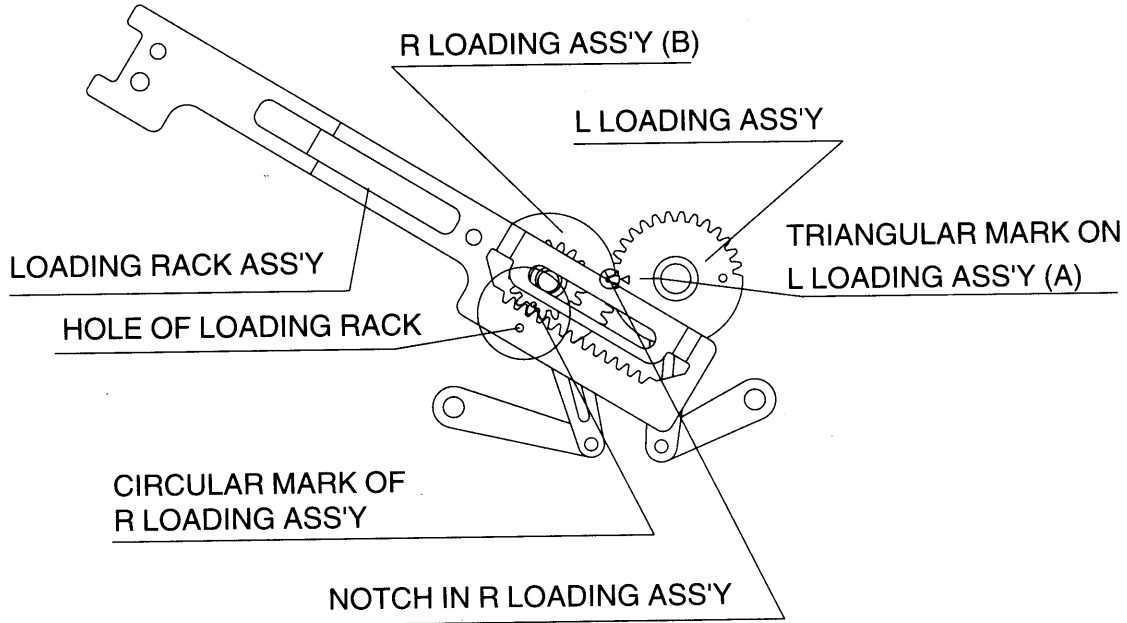

Fig.4-5 DATUM POSITION OF LOADING RACK ASS'Y & R/L LOADING LEVER ASS'YS

## 4-2. BACK TENSION MEASUREMENT (See Fig.4-6~4-7)

- Confirm that the position of the TENSION POLE is correctly POSITIONED. Refer to the "4-4 TENSION POLE POSITION ADJUSTMENT".
- Play back a T-120 TAPE at its center position without assembling F/L ASSEMBLY and wait until the TAPE running is stabilized (about 5~10 seconds).
- Bring the TENTELOMETER into contact with the TAPE (Fig.4-6) and measure the BACK TENSION. The measuring result should be between 25 and 33 grams.
- If the measuring result is not within this specification, refer to the NOTE below or repeat "4-4 TENSION POLE POSITION ADJUSTMENT". (Fig. 4-7)

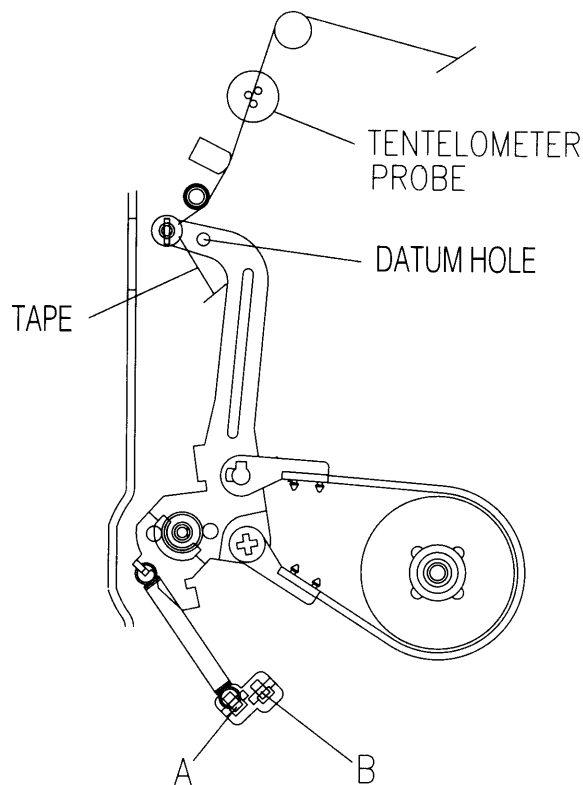

Fig.4-6 BACK TENSION MEASUREMENT

### NOTE:

- If the measuring result is not within the specification, change the TENSION SPRING position. (To decrease the result, choose hook A. Otherwise, choose hook B).
- Confirm that all of the three probes of the TENSION METER are in contact with the TAPE. During this process, don't touch any other parts of the MECHANISM (i.e, MAINBASE).
- It is recommended that this measurement be repeated at least three times for an accurate reading.

### 4-3. MECHANICAL MODE (OPERATING THE VCR WITHOUT A CASSETTE TAPE)

- a. Remove the FRONT LOADING MECHANISM from the DECK MECHANISM.
- b. Pull the F/L RACK.
- c. The S/T POLE BASES are loaded and PLAY BACK MODE starts.
- d. Turn off the power when the MECHANISM is in the desired position.

### 4-4. TENSION POLE POSITION ADJUSTMENT

- a. MAKE MECHANICAL MODE be PLAY MODE. Refer to "4-3 MECHANICAL MODE".
- b. Confirm that the datum hole of TENSION LEVER is aligned with the datum hole of the MAIN BASE.
- c. If requirement "b" is not satisfied, turn the BAND BRAKE ADJUST CAP clockwise or counter-clockwise until the two datum hole are aligned with each other.

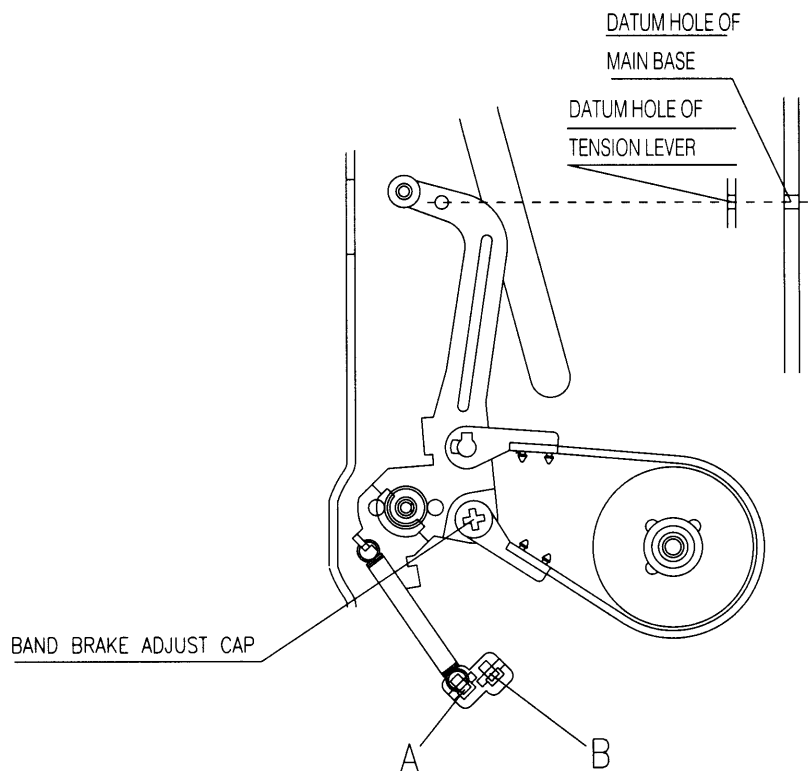

Fig. 4-7 TENSION POLE POSITION ADJUSTMENT

# 5. ADJUSTMENT OF TAPE TRANSPORTING SYSTEM

Generally the TAPE TRANSPORTING SYSTEM has been precisely adjusted in the factory and does not ordinarily require readjustment. But when noise and tape damage take place and part assemblies that compose the TAPE TRANSPORTING SYSTEM are replaced, check and readjust the TAPE TRANSPORTING SYSTEM. Refer to the following FLOW CHART in order to adjust the TAPE TRANSPORTING SYSTEM.

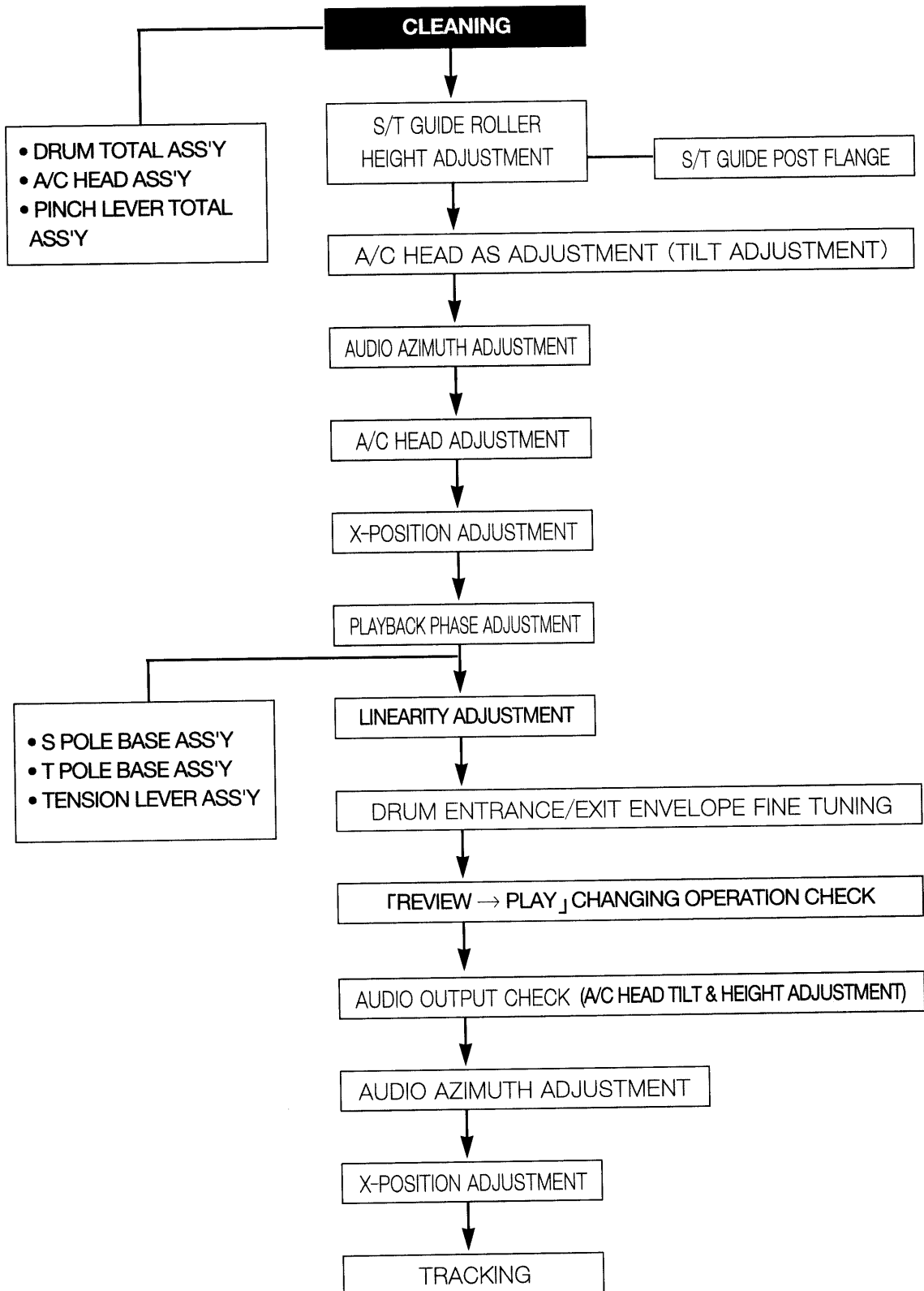

Table.1 ADJUSTMENT FLOW DIAGRAM OF THE TAPE TRANSPORTING SYSTEM

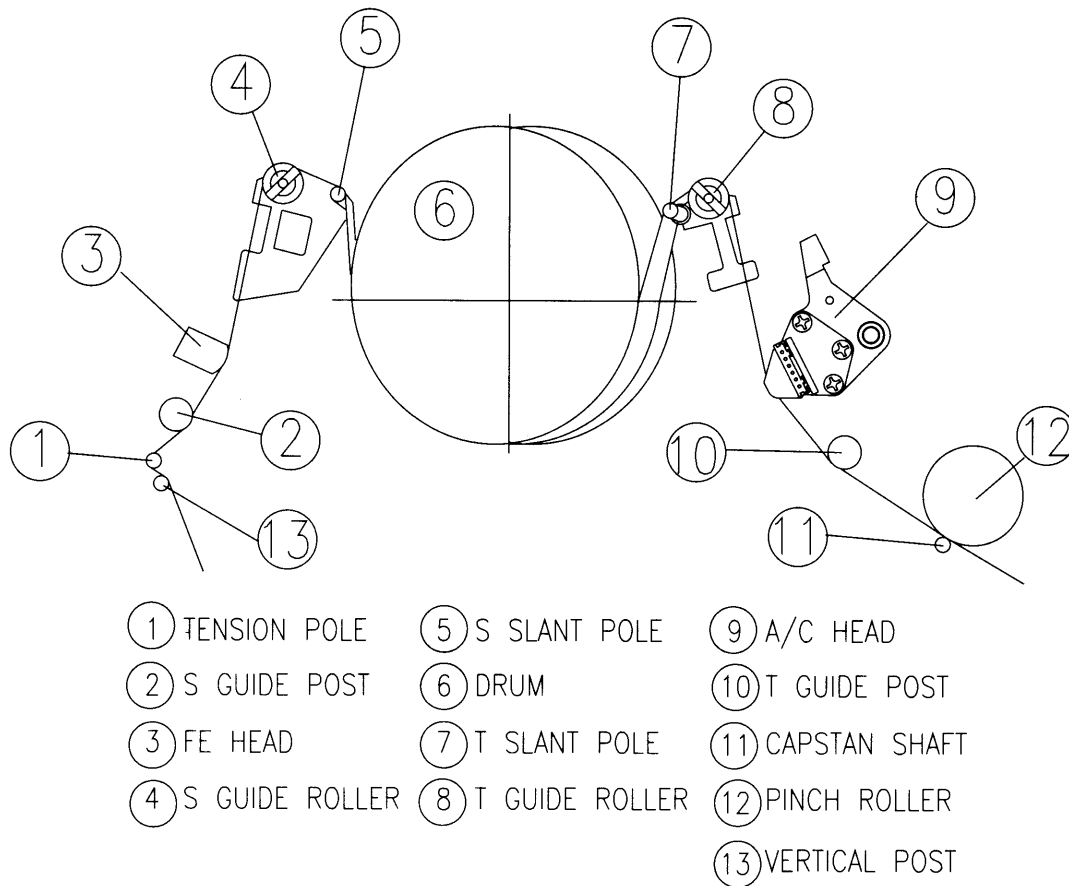

Fig. 5-1 THE SCHEMATIC DIAGRAM OF TAPE TRANSPORTING SYSTEM

When the parts as shown in Fig. 5-1 are replaced, the TAPE TRANSPORTING SYSTEM has changed. To prevent this, it is essential to know thoroughly and observe the following INSTRUCTIONS.

### A. ADJUSTMENT OF THE S/T GUIDE ROLLER

- a. Play back a T-120 TAPE.
- b. Make sure that excessive TAPE wrinkle does not occur at each S/T GUIDE ROLLER.
- c. If TAPE wrinkle is observed at the S/T GUIDE ROLLER, adjust them so that no wrinkle occurs.

## B. ADJUSTMENT OF THE A/C HEAD ASS'Y (TILT ADJUSTMENT)

- Play back a T-120 Tape and check the running condition of the TAPE at the lower flanges of the T GUIDE POST ASS'Y (II) in Fig. 5-1.
- Adjust the A/C HEAD TILT SCREW until the TAPE runs stable as shown in Fig. 5-2

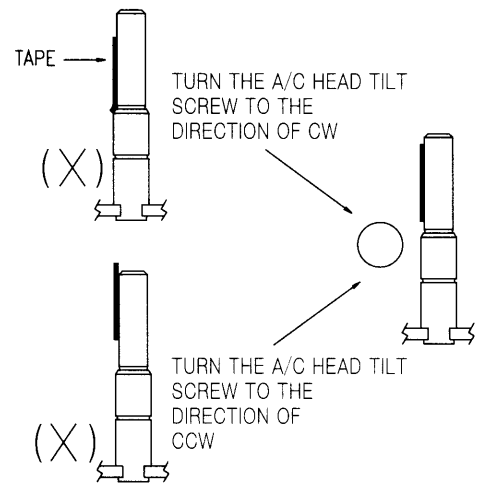
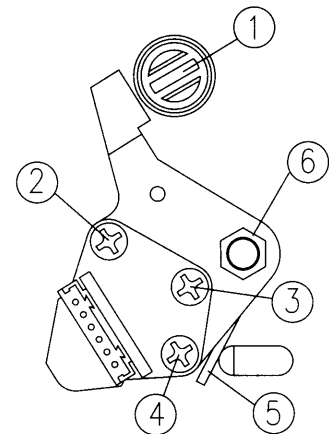

Fig. 5-2 A/C HEAD ASS'Y ADJUSTMENT (TILT ADJUSTMENT)

## C. ADJUSTMENT OF THE AUDIO AZIMUTH (See Fig.5-3)

- Play back the ALIGNMENT CASSETTE TAPE (NTSC: DN2 (SP, 7KHz), PAL: DP2 (SP, 6KHz))
- Observe audio signals on an OSCILLOSCOPE.
- Turn the A/C HEAD AZIMUTH SCREW to obtain the maximum audio output signal (-9~-3dBm).



- |                         |                  |
|-------------------------|------------------|
| ① ADJUST BOSS           | ④ FIXING SCREW   |
| ② AC HEAD AZIMUTH SCREW | ⑤ AC HEAD SPRING |
| ③ AC HEAD TILT SCREW    | ⑥ AC HEAD NUT    |

Fig. 5-3 A/C HEAD ASS'Y

## D. THE HEIGHT ADJUSTMENT OF A/C HEAD

- Play back a T-120 TAPE.
- Make sure that the gap is 0.25mm between the lower end of TAPE and that of A/C HEAD.
- When the gap is longer than 0.25mm, turn the A/C HEAD HEIGHT ADJUST NUT counter-clockwise. When the gap is shorter than 0.25mm, turn it clockwise. Repeat this procedure until 0.25mm is obtained.

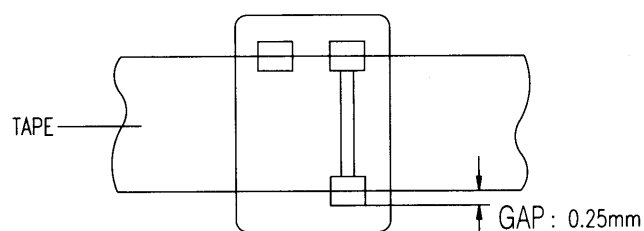

Fig. 5-4 A/C HEAD ASS'Y ADJUSTMENT (HEIGHT ADJUSTMENT)

## E. X-POSITION ADJUSTMENT

TEST POINTS	S/W PULSE TEST PIN	PATH ADJ. FIXTURE
	ENVELOPE TEST PIN	PATH ADJ. FIXTURE
MEASURING EQUIPMENT	OSCILLOSCOPE	
ADJUSTMENT	VR CONTROL	PATH ADJ. FIXTURE
	ADJUST BOSS	MAIN BASE.

- Connect the path adjustment fixture to PT01 of the MAIN CIRCUIT BOARD.
- Play back the ALIGNMENT TAPE (COLOR BAR ALIGNMENT).
- Connect channel-1 scope probe to S/W PULSE TEST PIN of PATH ADJ, FIXTURE.
- Connect channel-2 scope probe to ENVELOPE TEST PIN of PATH ADJ, FIXTURE.
- Turn the VR CONTROL to the center point. (If the VR CONTROL is completely turned counter-clockwise, it is positioned on another tracking center.)
- With the VR CONTROL in the center state, turn the ADJUST BOSS by using FLAT TYPE SCREW DRIVER and adjust the X-POSITION to obtain the maximum envelope waveform.

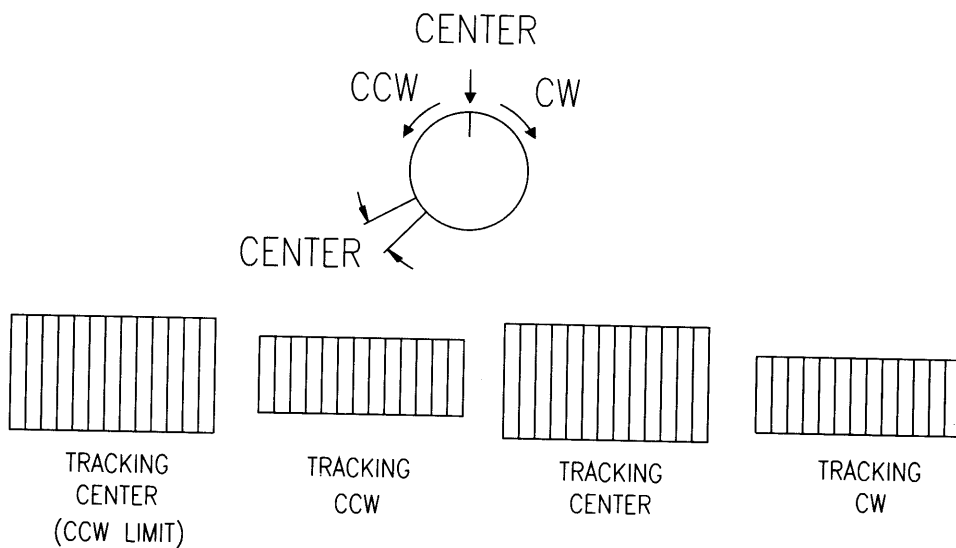

Fig. 5-5 X-POSITION ADJUSTMENT



## F. PLAYBACK PHASE ADJUSTMENT (See Fig. 5-6)

TEST POINTS	S/W PULSE TEST PIN	PATH ADJ. FIXTURE
	VIDEO OUT	MAIN CIRCUIT BOARD
MEASURING EQUIPMENT	OSCILLOSCOPE	
ADJUSTMENT	VR595 (PG SHIFTER)	MAIN CIRCUIT BOARD

Phase generator (PG) shifter decides the VIDEO HEAD switching point when a TAPE is played back. In case the Phase generator (PG) shifter isn't correctly tuned, HEAD switching noise or vertical jitter may occur.

- Connect the PATH ADJ. FIXTURE to PT01 of the MAIN CIRCUIT BOARD.
- Play the ALIGNMENT TAPE (COLOR BAR SIGNAL OR MONOSCOPE SIGNAL)
- Connect the channel-1 scope probe to the S/W PULSE TEST PIN of the PATH ADJ. FIXTURE.
- Connect the channel-2 scope probe(1V/div.) to the VIDEO OUT of the MAIN CIRCUIT BOARD.
- Play back the ALIGNMENT TAPE.
- Adjust the PG volume for time interval of  $6.5H \pm 0.5$  between switching pulse and V-sync signal.

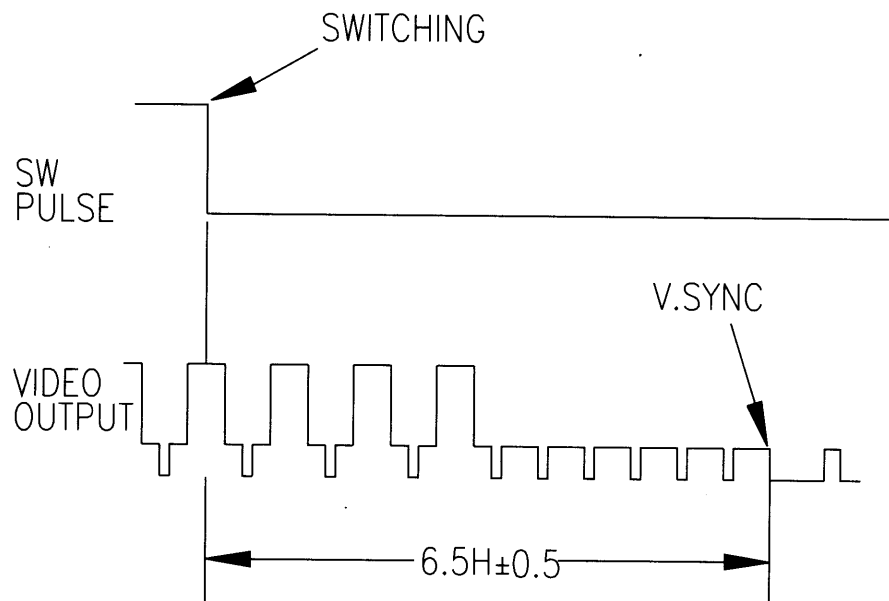

Fig. 5-6 PLAYBACK PHASE ADJUSTMENT

## G. LINEARITY ADJUSTMENT

TEST POINTS	S/W PULSE TEST PIN	PATH ADJ. FIXTURE
	ENVELOPE TEST PIN	PATH ADJ. FIXTURE
MEASURING EQUIPMENT	OSCILLOSCOPE	
ADJUSTMENT	VR CONTROL	PATH ADJ. FIXTURE
	S/T GUIDE ROLLER	TAPE TRANSPORTING SYSTEM

- Connect the PATH ADJ. FIXTURE to PT01 of the MAIN CIRCUIT BOARD.
- Play back the ALIGNMENT TAPE (COLOR BAR SIGNAL).
- Connect the channel-1 scope probe to the S/W PULSE TEST PIN of the PATH ADJ. FIXTURE.
- Connect the channel-2 scope probe to the ENVELOPE TEST PIN of the PATH ADJ. FIXTURE.
- Adjust the VR CONTROL of the PATH ADJ. FIXTURE for maximum envelope signal output of the alignment tape.
- Adjust the S/T GUIDE ROLLER until the envelope signal waveforms of the entrance and exit sides are as shown in Fig. 5-7.

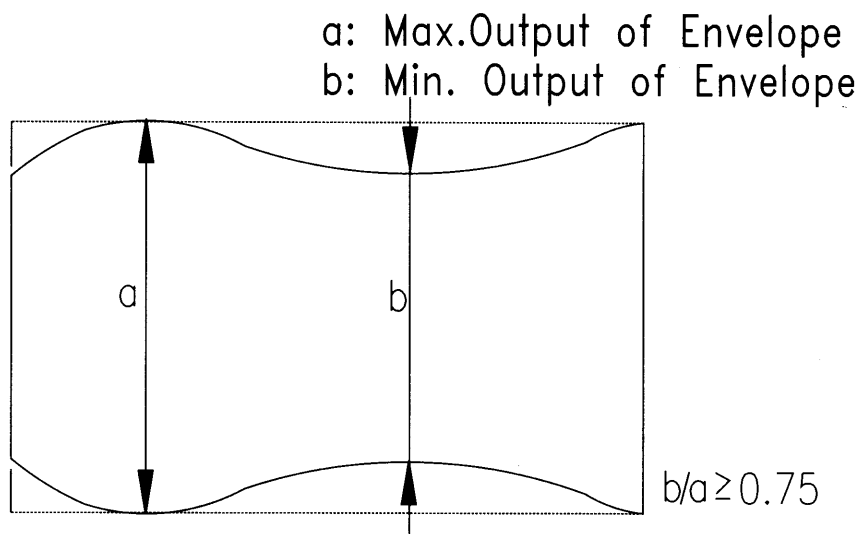

Fig. 5-7 LINEARITY ADJUSTMENT

## H. DRUM ENTRANCE /EXIT (See Fig. 5-8, 5-9)

TEST POINTS	S/W PULSE TEST PIN	PATH ADJ. FIXTURE
	ENVELOPE TEST PIN	PATH ADJ. FIXTURE
MEASURING EQUIPMENT	OSCILLOSCOPE	
ADJUSTMENT	VR CONTROL	PATH ADJ. FIXTURE
	S/T GUIDE ROLLER	TAPE TRANSPORTING SYSTEM

- Connect the PATH ADJ. FIXTURE to PT01 the MAIN CIRCUIT BOARD.
- Play back the ALIGNMENT TAPE (COLOR BAR SIGNAL).
- Connect the channel-1 scope probe to the S/W PULSE TEST PIN of the PATH ADJ. FIXTURE.
- Connect the channel-2 scope probe to the ENVELOPE TEST PIN of the PATH ADJ. FIXTURE.
- When turning the VR CONTROL of the PATH ADJ. FIXTURE clockwise or counter-clockwise, affirm that the envelope thickness changes uniformly.
- If the envelope is not uniform and regular, adjust the S/T GUIDE ROLLER.

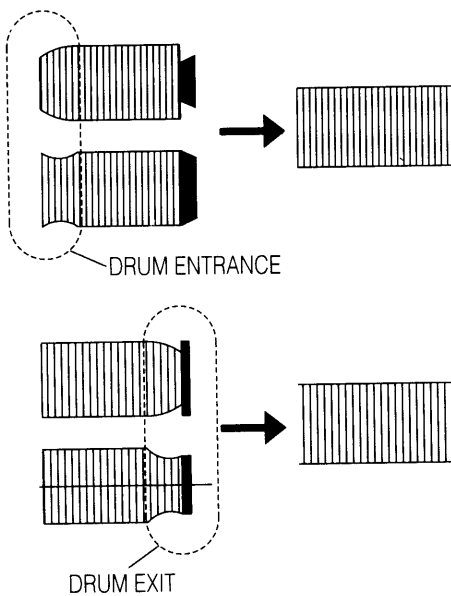

Fig. 5-8 FINE TUNING OF THE ENVELOPE AT THE DRUM ENTRANCE/EXIT (I)

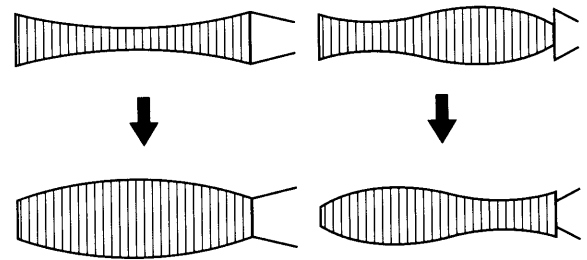

Fig.5-9 FINE TUNING OF THE ENVELOPE AT THE DRUM ENTRANCE/EXIT (II)

**I. REVIEW → PLAY (See Fig. 5-10)**

TEST POINTS	S/W PULSE TEST PIN	PATH ADJ. FIXTURE
	ENVELOPE TEST PIN	PATH ADJ. FIXTURE
MEASURING EQUIPMENT	OSCILLOSCOPE	
ADJUSTMENT	VR CONTROL	PATH ADJ. FIXTURE
	S/T GUIDE ROLLER	TAPE TRANSPORTIN SYSTEM

- Connect the PATH ADJ. FIXTURE to PT01 of the MAIN CIRCUIT BOARD.
- Play back the ALIGNMENT TAPE (SP, COLOR BAR SIGNAL).
- Connect the channel-1 scope probe to the S/W PULSE TEST PIN of the PATH ADJ. FIXTURE.
- Connect the channel-2 scope probe to the ENVELOPE TEST PIN of the PATH ADJ. FIXTURE.
- Adjust the VR CONTROL of the PATH ADJ. FIXTURE to the center to obtain the maximum envelope signal of the ALIGNMENT TAPE.
- After operating the VCR in the REVIEW MODE about 15 secs, change the REVIEW MODE to the PLAY BACK MODE.
- Change operation mode from REVIEW MODE to PLAY MODE and then make sure that the envelope waveform is restored to the maximum condition within 3 seconds.
- If the requirement is not satisfied, make sure that the TAPE runs normal at the lower part of the T GUIDE POST. Then adjust the S/T GUIDE ROLLER precisely.

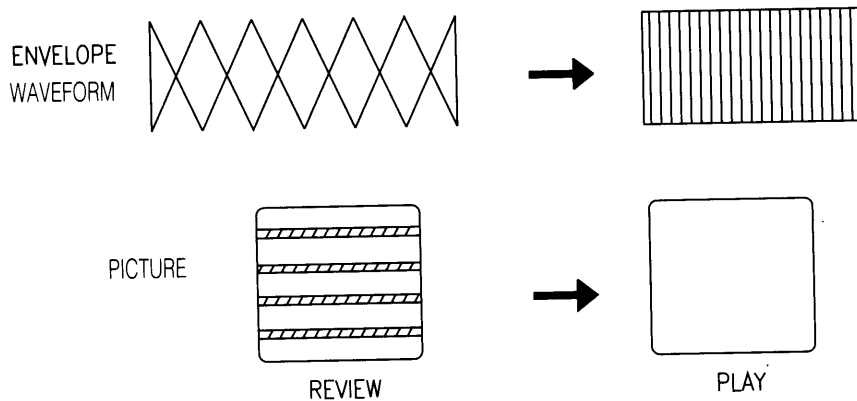

Fig. 5-10 CHECK OF TRANSITIONAL OPERATION (FROM REVIEW WAVEFORM TO PLAY WAVEFORM)

## J. AUDIO OUTPUT (A/C HEAD TILT & HEIGHT ADJUSTMENT)

TEST POINTS	AUDIO OUTPUT	AUDIO OUTPUT JACK
MEASURING EQUIPMENT	OSCILLOSCOPE	

- a. Connect the OSCILLOSCOPE to the AUDIO OUTPUT JACK.
- b. Play back the ALIGNMENT TAPE (NTSC: DN1 (SP, 1KHz), PAL: DP1 (SP, 1KHz)).
- c. Check the AUDIO OUTPUT SIGNAL is -9~-3dBm.
- d. If the requirement "c" is not satisfied, adjust the A/C HEAD TILT SCREW and A/C HEAD HEIGHT NUT to obtain the maximum audio output. (Fig. 5-3)

## K. A/C HEAD AZIMUTH ADJUSTMENT

- a. Connect the OSCILLOSCOPE to the AUDIO OUTPUT JACK.
- b. Play back the ALIGNMENT TAPE (NTSC: DN2 (SP, 7KHz), PAL: DP2 (SP, 6KHz)).
- c. Adjust the A/C HEAD AZIMUTH SCREW to obtain the audio output -9~-3dBm. (Fig. 5-3)
- d. Repeat the process "H. DRUM ENTRANCE/EXIT".

TEST POINTS	AUDIO OUTPUT	AUDIO OUTPUT JACK
MEASURING EQUIPMENT	OSCILLOSCOPE	

## L. X-POSITION (See Fig. 5-11)

TEST POINTS	S/W PULSE TEST PIN	PATH ADJ. FIXTURE
	ENVELOPE TEST PIN	PATH ADJ. FIXTURE
MEASURING EQUIPMENT	OSCILLOSCOPE	
ADJUSTMENT	VR CONTROL	PATH ADJ. FIXTURE
	ADJUST BOSS	MAIN BASE.

- Connect the PATH ADJ. FIXTURE to PT01 of the MAIN CIRCUIT BOARD.
- Play back the ALIGNMENT TAPE (COLOR SIGNAL BAR).
- Connect the channel-1 scope probe to the S/W PULSE TEST PIN of the of the PATH ADJ. FIXTURE.
- Connect the channel-2 scope probe to the ENVELOPE TEST PIN of the PATH ADJ. FIXTURE.
- Adjust the VR CONTROL to the center position. (When the VR CONTROL is completely turned counter-clockwise, it is set at another tracking center position).
- When the VR CONTROL is fully rotated clockwise or counter-clockwise, turn the ADJUST BOSS of the MAINBASE and adjust the X-POSITION for the envelope waveform to be as shown in Fig. 5-11
- Repeat the process "F. PLAYBACK PHASE ADJUSTMENT".

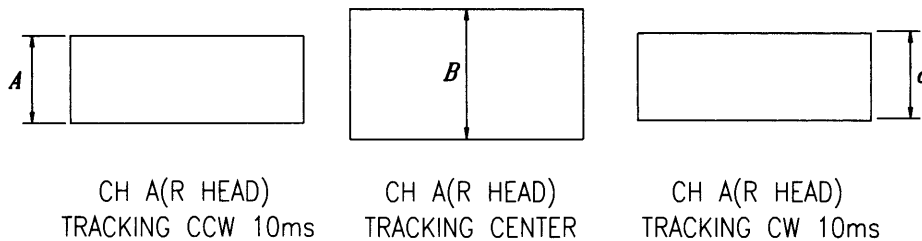
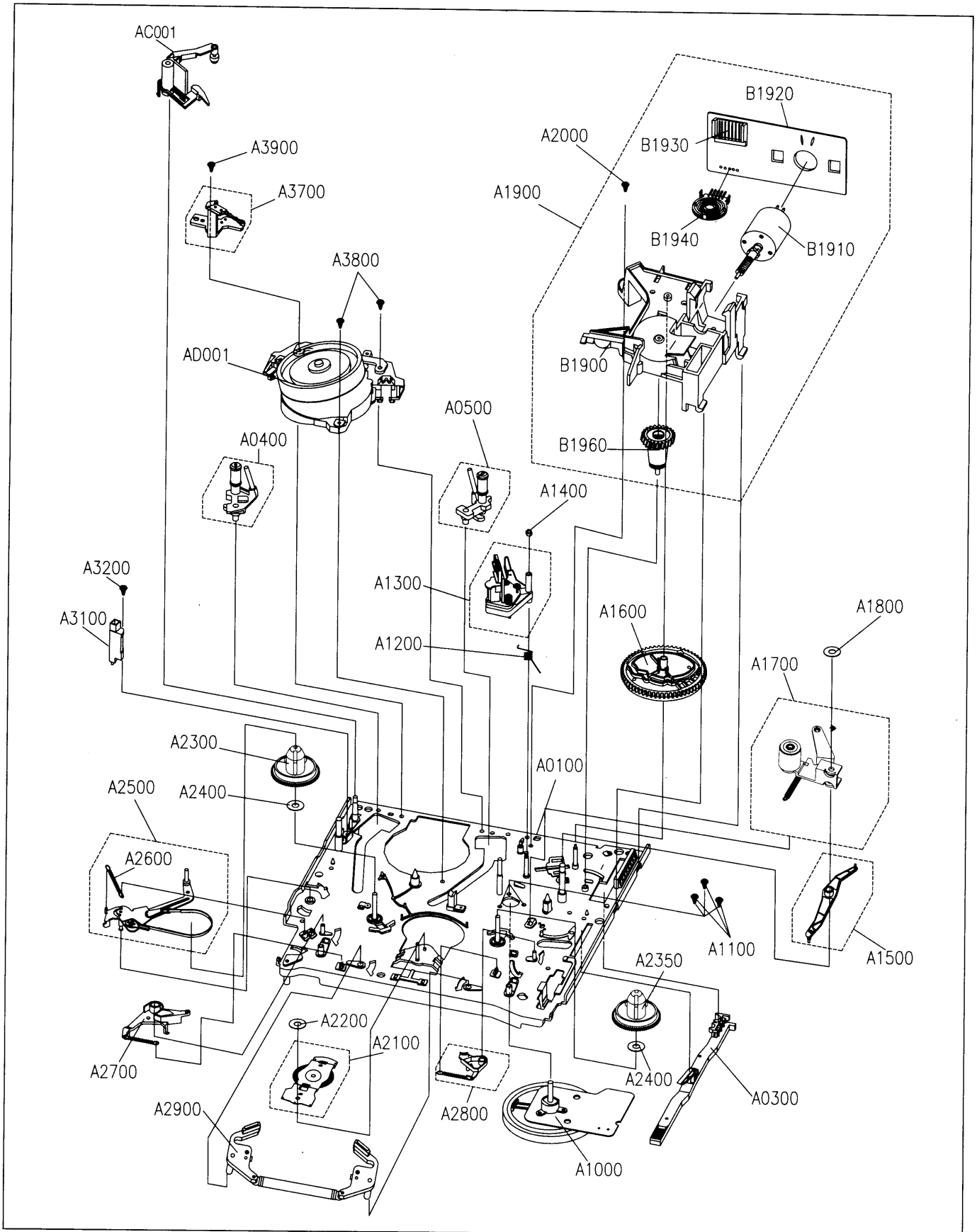

Fig. 5-11 X-POSITION ADJUSTMENT

# 6. EXPLODED VIEW AND PARTS LIST

## 6-1. EXPLODED VIEW OF DECK ASS'Y (TOP VIEW)



## 6-2. EXPLODED VIEW OF DECK ASS'Y (BOTTOM VIEW)

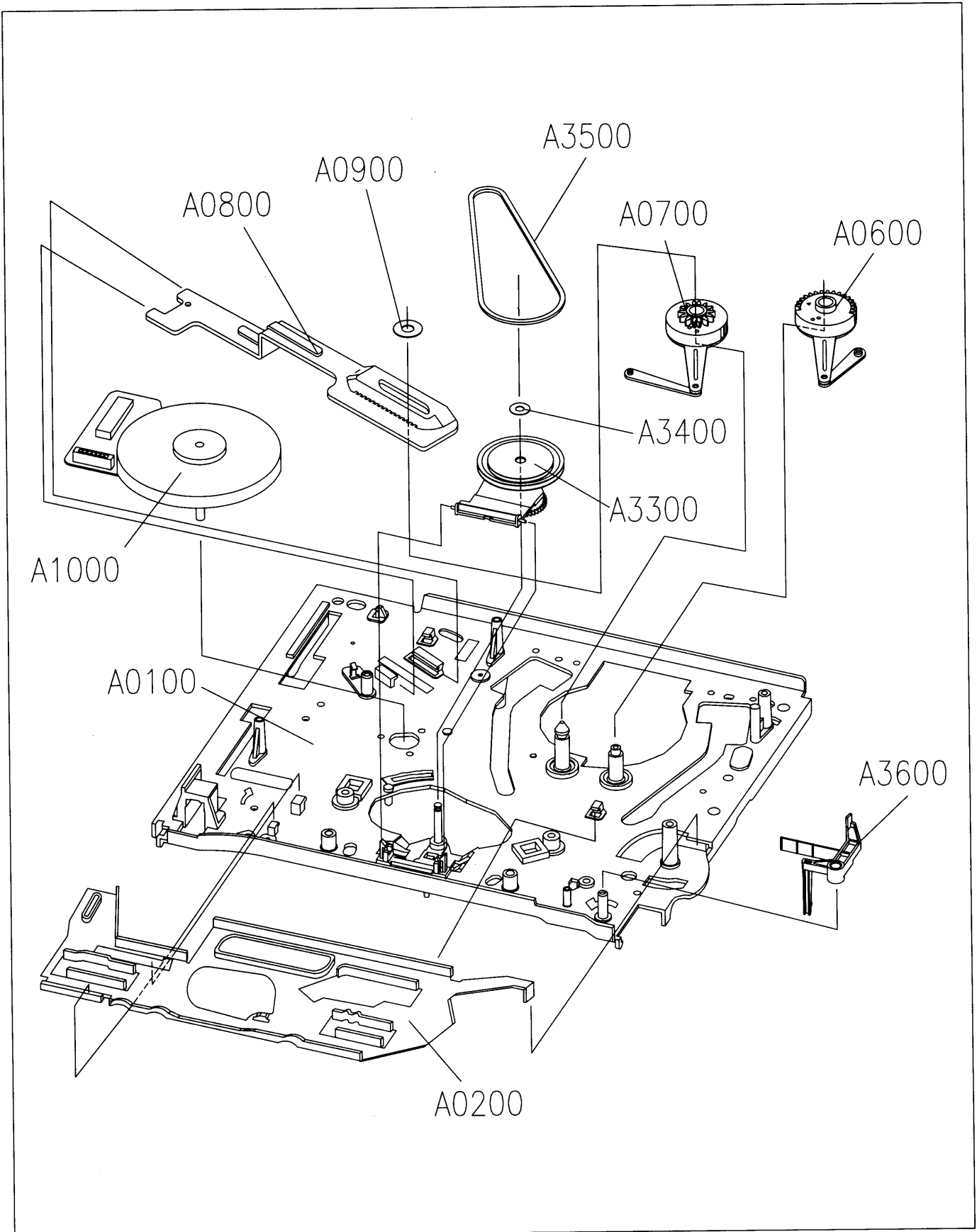



### 6-3. EXPLODED VIEW OF F/L ASS'Y

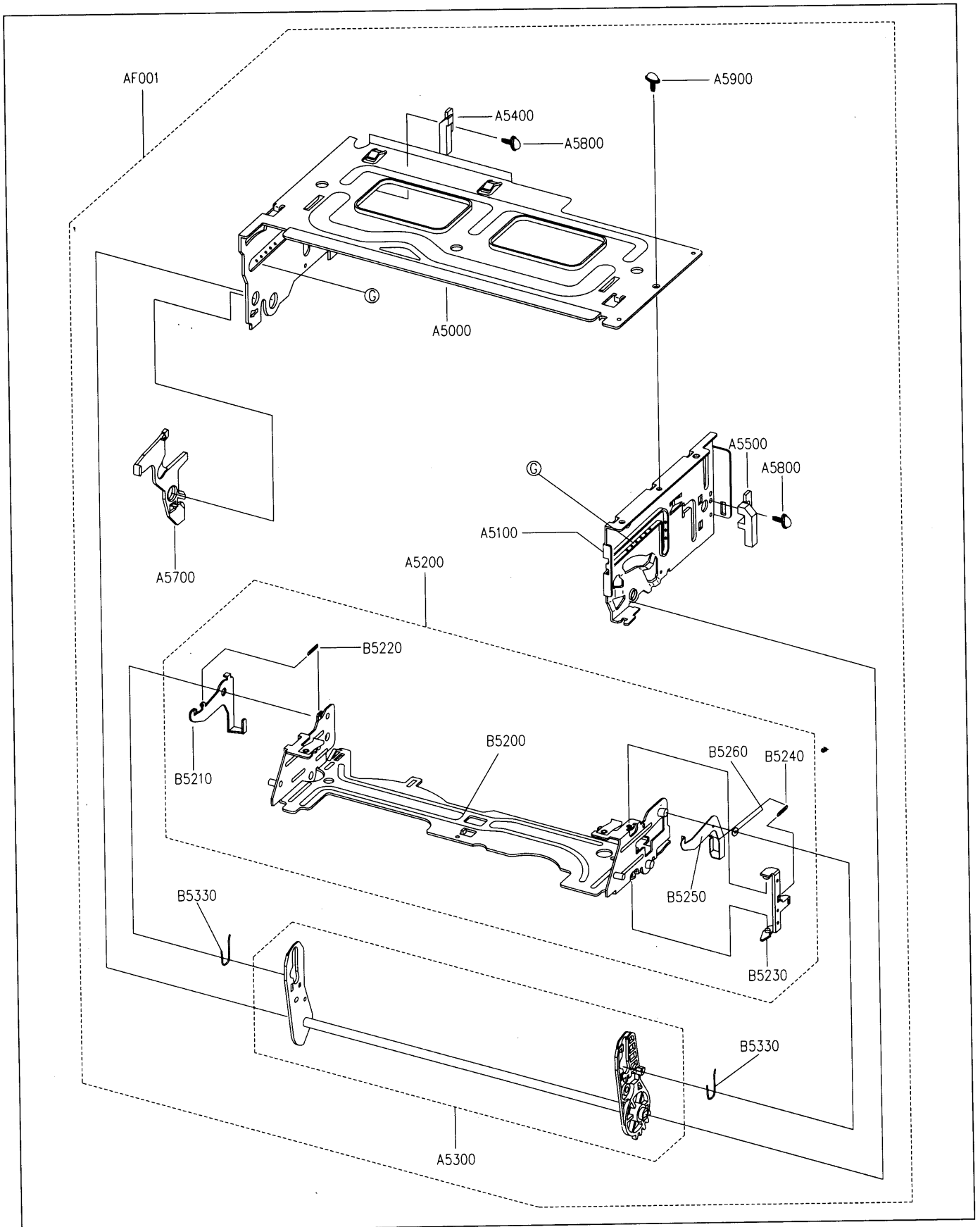

AD001

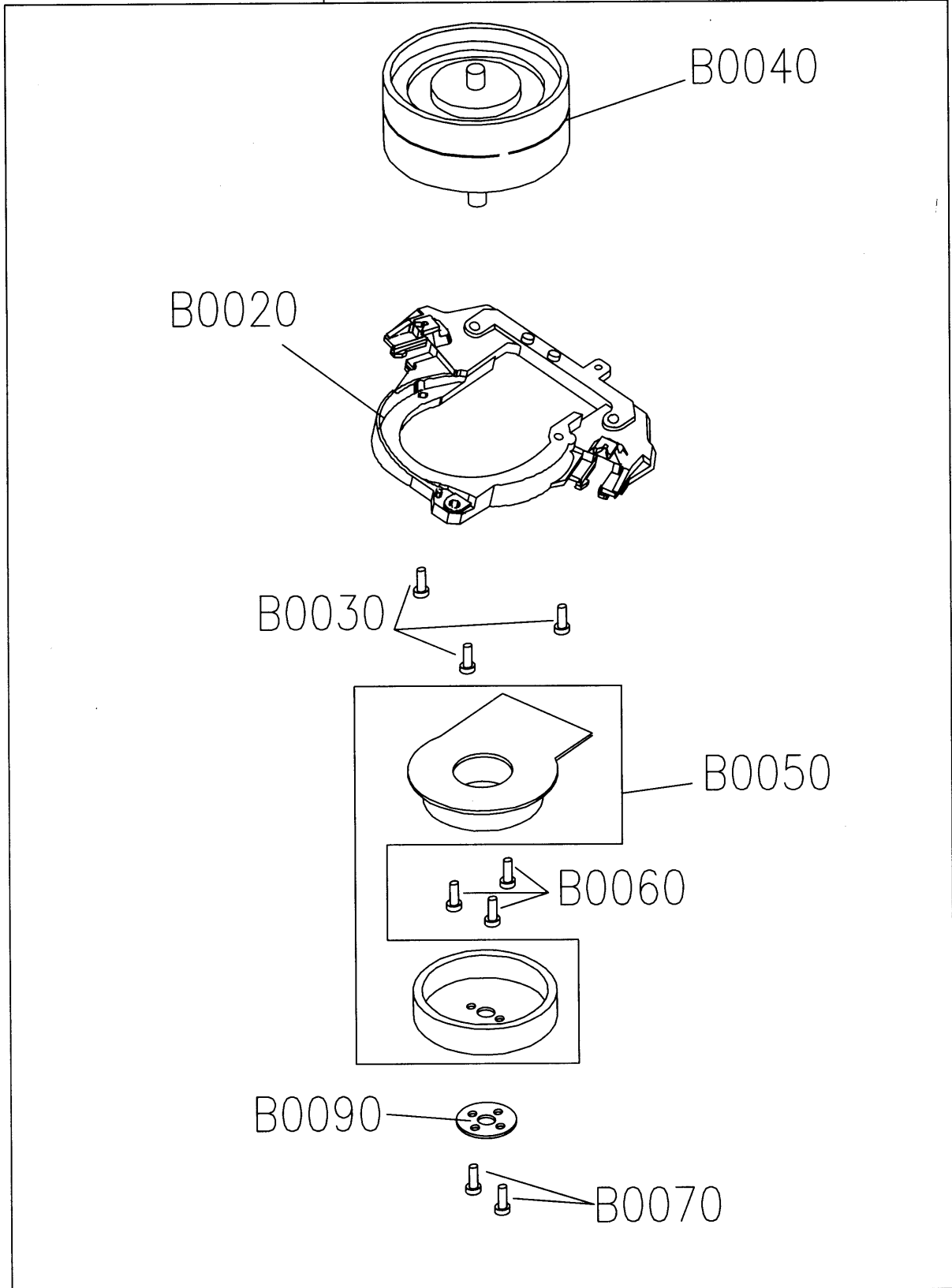

## 6-4-1. PARTS LIST OF DECK TOTAL ASS'Y

LOC.	STOCK NO.	PART NAME	DESCRIPTION
NTSC			
M1000	97PC0048D-	DECK TOTAL AS	DRN-7203 (HT 2 HD EP NON-DLC)
M1000	97PC0186D-	DECK TOTAL AS	DPN-7204 “(HT 2 HD EP NON-DLC, HEAD CLNR, VCP)”
M1000	97PC0187D-	DECK TOTAL AS	DRN-7204 “(HT 2 HD EP NON-DLC, HEAD CLNR)”
M1000	97PC0218D-	DECK TOTAL AS	DPN-7206 “(2 HD EP NON-DLC, HEAD CLNR, VCP, SQPB)”
M1000	97PC0116D-	DECK TOTAL AS	DRN-7223 (HT 2 HD EP DLC)
M1000	97PC0117D-	DECK TOTAL AS	DRN-7233 (HT 2 HD EP DLC-BK)
M1000	97PB0884D-	DECK TOTAL AS	DRN-7400 (4 HD MONO NON-DLC)
M1000	97PC0108D-	DECK TOTAL AS	DRN-7401 “(4 HD MONO NON-DLC, HEAD CLNR)”
M1000	97PB0892D-	DECK TOTAL AS	DRN-7420 (4 HD MONO DLC)
M1000	97PC0109D-	DECK TOTAL AS	DRN-7421 “(4 HD MONO DLC, HEAD CLNR)”
M1000	97PC0063D-	DECK TOTAL AS	DRN-7430 (4 HD MONO DLC-BK)
M1000	97PB0887D-	DECK TOTAL AS	DRN-7600 (4 HD HI-FI NON-DLC)
M1000	97PC0050D-	DECK TOTAL AS	DRN-7603 (HT 4 HD HI-FI NON-DLC)
M1000	97PC0110D-	DECK TOTAL AS	DRN-7604 “(HT 4 HD HI-FI NON-DLC, HEAD CLNR)”
M1000	97PC0090D-	DECK TOTAL AS	DRN-7623 (HT 4 HD HI-FI DLC)
M1000	97PC0111D-	DECK TOTAL AS	DRN-7624 “(HT 4 HD HI-FI DLC, HEAD CLNR)”
M1000	97PC0064D-	DECK TOTAL AS	DRN-7630 (4 HD HI-FI DLC-BK)
M1000	97PC0107D-	DECK TOTAL AS	DRN-7633 (HT 4 HD HI-FI DLC-BK)

LOC.	STOCK NO.	PART NAME	DESCRIPTION
<b>PAL</b>			
M1000	97PC0069D-	DECK TOTAL AS	DRP-7103 (HT 2 HD SP MONO NON-DLC)
M1000	97PC0184D-	DECK TOTAL AS	DPP-7104 “(HT 2 HD SP MONO NON-DLC, HEAD CLNR, VCP)”
M1000	97PC0182D-	DECK TOTAL AS	DRP-7104 “(HT 2 HD SP MONO NON-DLC, HEAD CLNR)”
M1000	97PC0059D-	DECK TOTAL AS	DRP-7123 (HT 2 HD SP MONO DLC)
M1000	97PC0085D-	DECK TOTAL AS	DRP-7124 “(HT 2 HD SP MONO DLC, HEAD CLNR)”
M1000	97PC0068D-	DECK TOTAL AS	DRP-7203 (HT 2 HD SP/LP MONO NON-DLC)
M1000	97PC0060D-	DECK TOTAL AS	DRP-7223 (HT 2 HD SP/LP MONO DLC)
M1000	97PC0058D-	DECK TOTAL AS	DRP-7321 “(2 HD HI-FI DLC, HEAD CLNR)”
M1000	97PC0183D-	DECK TOTAL AS	DRP-7322 (2 HD HI-FI DLC)
M1000	97PC0086D-	DECK TOTAL AS	DRP7301 “(2 HD HI-FI NON-DLC, HEAD CLNR)”
M1000	97PC0072D-	DECK TOTAL AS	DRP-7400 (4 HD MONO NON-DLC)
M1000	97PC0192D-	DECK TOTAL AS	DRP-7401 “(4 HD MONO NON-DLC, HEAD CLNR)”
M1000	97PC0073D-	DECK TOTAL AS	DRP-7420 (4 HD MONO DLC)
M1000	97PC0130D-	DECK TOTAL AS	DRP-7421 “(4 HD MONO DLC, HEAD CLNR)”
M1000	97PC0070D-	DECK TOTAL AS	DRP-7603 (HT 4 HD HI-FI NON-DLC)
M1000	97PC0207D-	DECK TOTAL AS	DRP-7604 “(HT 4 HD HI-FI NON-DLC, HEAD CLNR)”
M1000	97PC0071D-	DECK TOTAL AS	DRP-7623 (HT 4 HD HI-FI DLC)
M1000	97PC0209D-	DECK TOTAL AS	DRP-7624 “(HT 4 HD HI-FI DLC, HEAD CLNR)”

LOC.	STOCK NO.	PART NAME	DESCRIPTION
<b>SECAM</b>			
M1000	97PC0074D-	DECK TOTAL AS	DRS-7400 (4 HD MONO NON-DLC)
M1000	97PC0075D-	DECK TOTAL AS	DRS-7420 (4 HD MONO DLC)
M1000	97PC0189D-	DECK TOTAL AS	DRS-7603 (HT 4 HD HI-FI NON-DLC)
M1000	97PC0054D-	DECK TOTAL AS	DRS-7623 (HT 4 HD HI-FI DLC)

### 6-4-2. PARTS LIST OF DRUM PRICE ASS'Y

LOC.	STOCK NO.	PART NAME	DESCRIPTION
<b>NTSC</b>			
AD001	97PA255101	DRUM PRICE AS	CYN-K210H (HT 2 HD EP NON-DLC)
AD001	97PA266601	DRUM PRICE AS	CYN-K210SQ “(2 HD EP NON-DLC, SQPB)”
AD001	97PA258971	DRUM PRICE AS	CYN-K212H (HT 2 HD EP DLC)
AD001	97PA259041	DRUM PRICE AS	CYN-K213H (HT 2 HD EP DLC-BK)
AD001	97PA251801	DRUM PRICE AS	CYN-K410 (4 HD MONO NON-DLC)
AD001	97PA252471	DRUM PRICE AS	CYN-K412 (4 HD MONO DLC)
AD001	97PA258541	DRUM PRICE AS	CYN-K413 (4 HD MONO DLC-BK)
AD001	97PA251701	DRUM PRICE AS	CYN-K610 (4 HD HI-FI NON-DLC)
AD001	97PA257601	DRUM PRICE AS	CYN-K610H (HT 4 HD HI-FI NON-DLC)
AD001	97PA257771	DRUM PRICE AS	CYN-K612H (HT 4 HD HI-FI DLC)
AD001	97PA258641	DRUM PRICE AS	CYN-K613 (4 HD HI-FI DLC-BK)
AD001	97PA260741	DRUM PRICE AS	CYN-K613H (HT 4 HD HI-FI DLC-BK)

LOC.	STOCK NO.	PART NAME	DESCRIPTION
<b>PAL</b>			
AD001	97PA258701	DRUM PRICE AS	CYP-K110H (HT 2 HD SP MONO NON-DLC)
AD001	97PA255271	DRUM PRICE AS	CYP-K112H (HT 2 HD SP MONO DLC)
AD001	97PA258801	DRUM PRICE AS	CYP-K210H (HT 2 HD SP/LP MONO NON-DLC)
AD001	97PA255371	DRUM PRICE AS	CYP-K212H (HT 2 HD SP/LP MONO DLC)
AD001	97PA254071	DRUM PRICE AS	CYP-K312 (2 HD HI-FI DLC)
AD001	97PA260501	DRUM PRICE AS	CYP-K310 (2 HD HI-FI NON-DLC)
AD001	97PA253101	DRUM PRICE AS	CYP-K410 (4 HD MONO NON-DLC)
AD001	97PA253271	DRUM PRICE AS	CYP-K412 (4 HD MONO DLC)
AD001	97PA253301	DRUM PRICE AS	CYP-K610H (HT 4 HD HI-FI NON-DLC)
AD001	97PA253471	DRUM PRICE AS	CYP-K612H (HT 4 HD HI-FI DLC)
<b>SECAM</b>			
AD001	97PA253501	DRUM PRICE AS	CYS-K410 (4 HD MONO NON-DLC)
AD001	97PA253671	DRUM PRICE AS	CYS-K412 (4 HD MONO DLC)
AD001	97PA278201	DRUM PRICE AS	CYS-K610 (HT 4 HD HI-FI NON-DLC)
AD001	97PA278371	DRUM PRICE AS	CYS-K612 (HT 4 HD HI-FI DLC)

### 6-4-3. PARTS LIST OF DECK TOTAL ASS'Y

LOC.	STOCK NO.	PART NAME	DESCRIPTION
<b>DRUM PRICE AS</b>			
B0020	97S1401700	DRUM BASE	"K, FM-M(NON-MACHINING,ADC)"
B0030	7001300811	MACHINE SCREW	PAN 3X8 MFZN
B0050	97SA310600	DRUM MOTOR AS	SDV-0306A
	97SA312000	DRUM MOTOR AS	E20XL18
	97SA319100	DRUM MOTOR AS	GDV-D01A
B0060	7001261011	MACHINE SCREW	PAN 2.6X10 MFZN
B0070	7051260811	MACHINE SCREW	PAN 2.6X8 SW MFZN
B0090	97SA305400	DAMPER DYNAMIC AS	"SECC T1.2, LUMMIRROR T0.25"
B0040		DRUM AS	(REFERRING TO LIST OF DRUM PRICE ASS'Y)\
<b>F/L AS</b>			
AF001	97SA251400	F/L AS	K-MECHA
<b>DECK AS</b>			
AM001		DECK AS	(REFERRING TO LIST OF DECK TOTAL ASS'Y)
A0100	97SA309700	MAIN BASE AS	K-MECHA
A0200	97S0901400	PLATE CONNECY	SECC T1.0
A0300	97S2701800	RACK F/L	PBT(KP213G30) NATURAL
A0400	97SA310900	S SLANT POLE AS	K-MECHA
A0500	97SA311000	T SLANT POLE AS	K-MECHA
A0600	97SA308500	L LOADING AS	K-MECHA
A0700	97SA308600	R LOADING AS	K-MECHA
A0800	97SA308400	LOADING RACK AS	K-MECHA
A0900	97S3101800	WASHER POLY	D3.1XD8XT0.5
A1000	97S8100700	MOTOR CAPSTAN	F2QTB12
	97S8101200	MOTOR CAPSTAN	DMVCMC06ER
A1100	97S3102000	SCREW TAPTITE	TT2 BIN-P 2.6X7 MFZN
A1200	97S3004000	SPG AC HEAD	SUS304WPB D1.2
A1300	97SA311200	AC HEAD AS	K-MECHA
	97SA318700	AC HEAD AS	K-MECHA(KUGAMI)
	97SA311300	AC HEAD AS	K-MECHA(VCP)
A1400	7391300211	NUT HEX	6N-1-5 MFZN
A1500	97S2604100	LEVER RELAY	ZDC-2
A1600	97S2701400	GEAR CAM	DELIN 500 NATURAL
A1700	97SA310700	PINCH LEVER TOT AS	K-MECHA

LOC.	STOCK NO.	PART NAME	DESCRIPTION
A1800	97S3117300	WASHER POLY	D3.6XD8XT0.5
A1900	97SA310400	L/C BRKT TOT AS	K-MECHA
B1905	97SA414100	L/C BRKT AS	K-MECHA
B1910	97PA409200	L/C MOTOR AS	K-MECHA
B1920	97P6538222	L/C MOTOR PCB	PHENOL T1.6
B1930	97P6271500	CONN WAFER(ANGLE)	00-8283-0711-0000
B1940	5SSFF1DKM10	CAM SWITCH	MMS00320ZMBO
B1960	97S9201500	WORM WHEEL	DELIN 100 NATURAL
A2000	7274300611	SCREW TAPTITE	TT3 RND 3X6 MFZN
A2100	97SA311600	IDLER PLATE AS	K-MECHA
A2200	97S3108200	WASHER POLY	D2.6XD6XT0.5
A2300	97S2901600	TABLE REEL	F20 BLACK
A2400	97S3903600	POLY SLIDER	D3.1XD6XT0.5
A2500	97SA310800	TENSION BAND AS	K-MECHA
B2500	97SA409800	TENSION LEVER AS	K-MECHA
B2510	97SA409700	BAND BRAKE AS	K-MECHA
B2520	97S0400700	BAND BRAKE CAP	DURACON M90-02 NATURAL
A2600	97S3003500	SPG TENSION	SWPB D0.4
A2700	97SA309300	S SUB BRAKE AS	K-MECHA
A2800	97SA309400	T SUB BRAKE AS	K-MECHA
A2900	97SA309110	MAIN BRAKE AS	K-MECHA
A3100	97S8012900	HEAD FE	HVFHF0004AK
	97S8004500	HEAD FE	MH-132D
A3200	97S3102100	SCREW TAPTITE	TT2 BIN-P 2.6X10 MFZN
A3300	97SA309000	REEL GEAR TOT AS	K-MECHA
A3400	97S3108200	WASHER POLY	D2.6XD6.0XT0.5
A3500	97S5500400	BELT REEL	CR68
A3600	97S2603500	LEVER RECORD SAFETY	F20-03 NATURAL
A3700	97SB381100	EARTH BRCKET AS	"G,FM,K-MECHA"
A3800	7274301011	SCREW TAPTITE	TT3 RND 3X10 MFZN
A3900	7274301211	SCREW TAPTITE	TT3 RND 3X12 MFZN
A4000	7274300611	SCREW TAPTITE	TT3 RND 3X6 MFZN
A4100	2291129004	OIL LUBRICANT	OA-305P
A4200	2291131304	GREASE	DELUX 5221G(NAM-YOUNG)
<b>HEAD CLEANER AS</b>			
AC001	97SA381500	HEAD CLEANER AS	"K,FM-MECHA"